

F
FOWLER # 5666

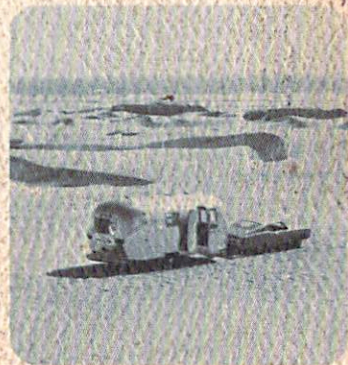

a guide to trailering in your 1969 AIRSTREAM



OWNERS MANUAL

REMOVE PROTECTIVE STRIP FROM TAPE ON THE WAR-
RANTY AND PLACE WARRANTY ON THIS PAGE AS SHOWN
AS SHOWN.

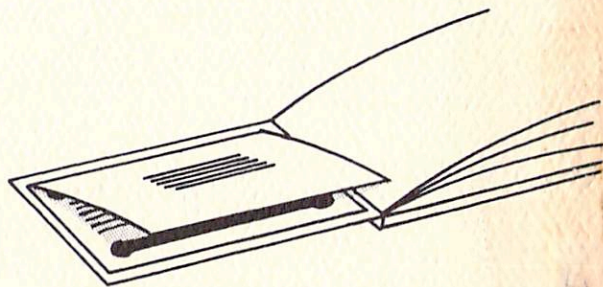

Ball Mount
no. 5508-A 2" ball

Cooper Bars
Cape - R-side
28 lb gas tanks

Front window shield just
off the window when open
any 3 position.

THIS MANUAL DESIGNED SPECIFICALLY FOR
USE WITH FOLLOWING AIRSTREAM MODELS



AIRSTREAM INC.
JACKSON CENTER, OHIO • CERRITOS, CALIF.

- 23 FT..... SAFARI
- 25 FT..... TRADE WIND
- 27 FT..... OVERLANDER
- 29 FT..... AMBASSADOR
- 31 FT..... SOVEREIGN

PRICE OF THIS MANUAL IS \$5.00
©AIRSTREAM INC., 1968

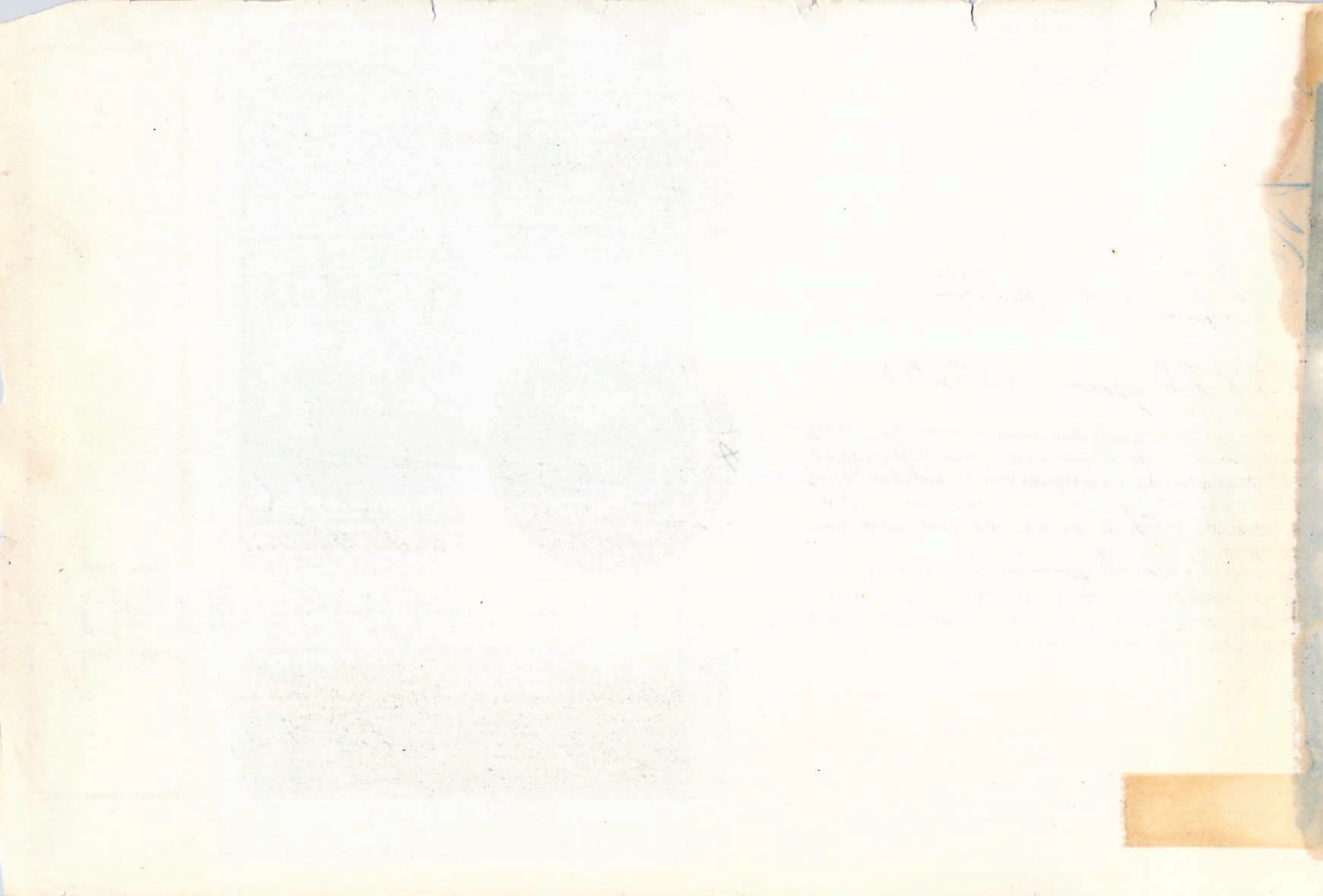

When you bought your Airstream, you not only received the finest travel trailer ever built, but you entered a new way of life . . . a way of life filled with friends and adventures to come.

In order to get the most carefree adventures from your new Airstream we suggest you get to know it thoroughly. This manual will aid you in doing so,

It contains operating and maintenance instructions which you will want to refer to from time to time to supplement the instructions your dealer gave you. In addition, it has tips on travel trailering drawn from the experiences of tens of thousands of people like you, who have taken their Airstreams into every corner of the world.

Should you trade or sell your trailer, be sure to pass this manual along to the new owner. When you've read it through, you will know how valuable it can be in getting better acquainted with the Airstream.

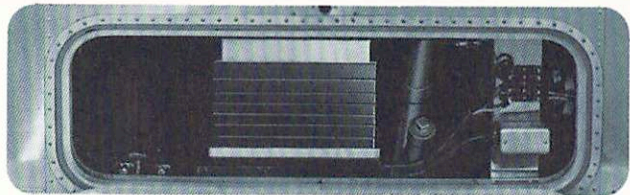
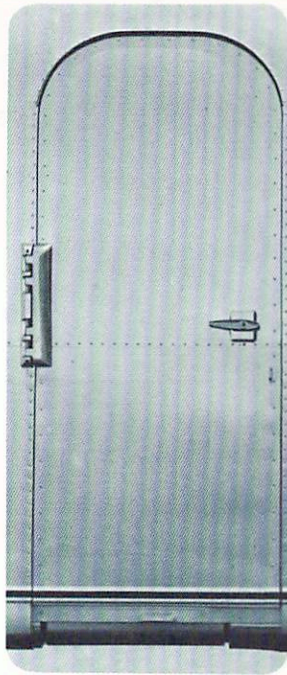
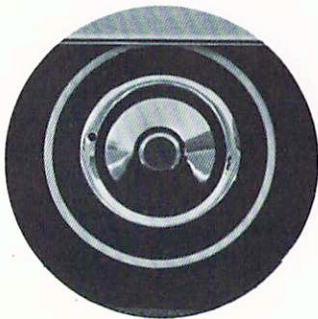
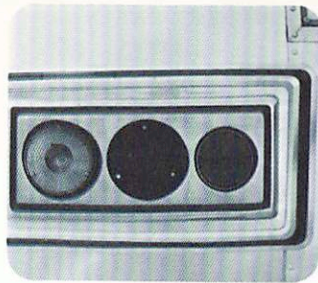

FOREWORD

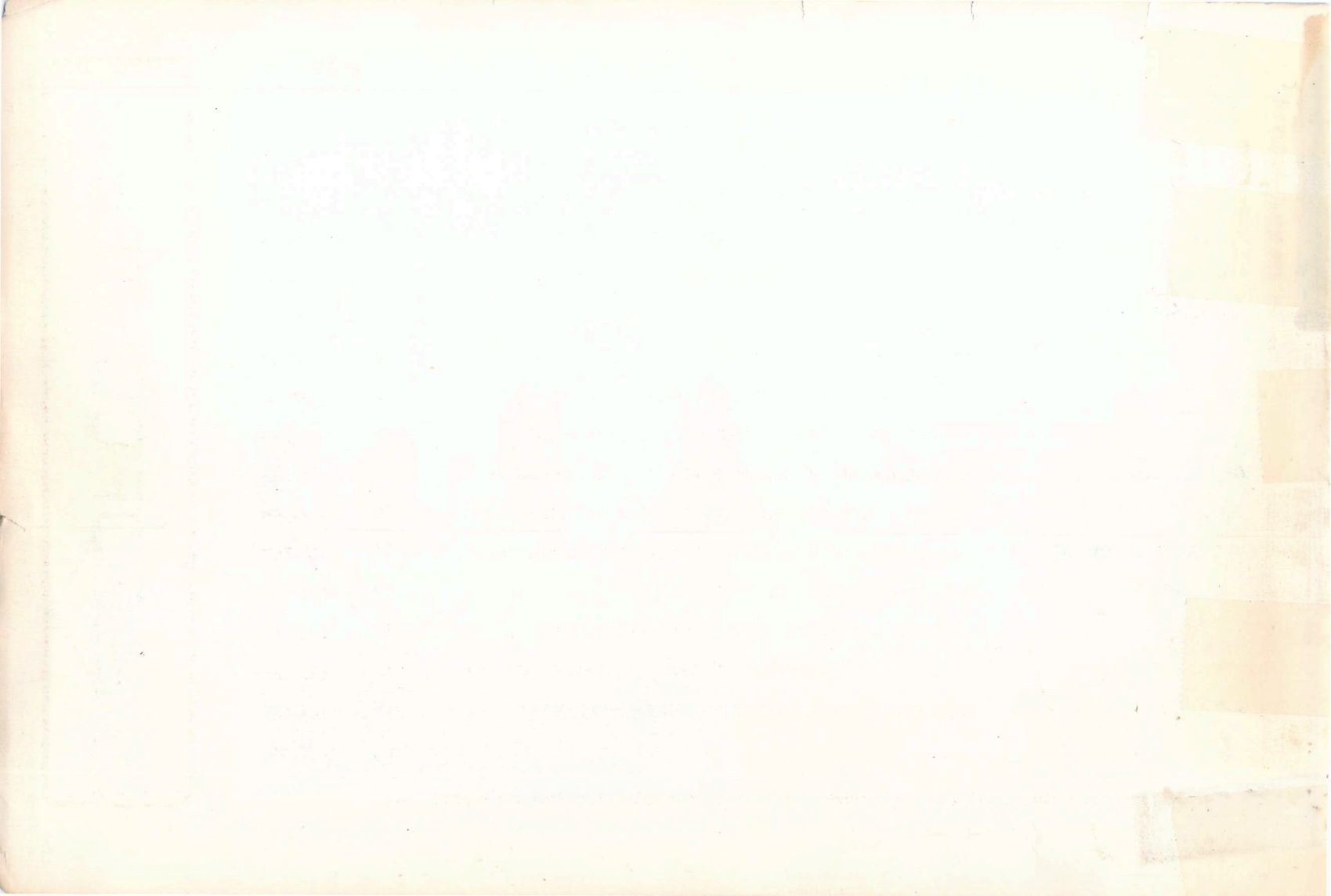

	CHAPTER	PAGE
		FROM — TO
FOREWORD:		3
WALLY BYAM CARAVANS & CLUBS:	1	9-11
SERVICE: C.P.C. PROGRAM, FACTORY SERVICE, SERVICE CENTERS	2	15-19
EQUIPPING TRAILER FOR ROAD: OUTFITTING TRAILER, EQUIPMENT LIST, ACCESSORIES	3	23-25
TOWING TIPS: HITCHING, LOADING, TOWING, OVERHEATING, STATE LAWS	4	29-44
OVERNIGHT STOP — EXTENDED STAY: LEVELING TRAILER	5	47-49
L.P.G. SYSTEM: CHANGING TANKS, DIAGRAMS	6	53-56
ELECTRICAL SYSTEM: LIGHTS, SELF-CONTAINED, CITY POWER, DIAGRAMS	7	59-67
WATER SYSTEM: CITY WATER, SELF-CONTAINED, PURIFIER, DIAGRAMS	8	71-75
DRAINAGE SYSTEM: CITY SEWER, SELF-CONTAINED, TOILET FLUSH, DIAGRAMS	9	79-84
APPLIANCES: FURNACE, REFRIGERATOR, RANGE & OVEN, WATER HEATER	10	87-98
RUNNING GEAR & HARDWARE: AXLES, BRAKES, TIRES, DOORS, WINDOWS, T.V. ANTENNA	11	101-107
TRAILER STORAGE-WINTERIZING: WATER DRAIN, BATTERY	12	111-112
EQUIPPING TOW CAR: HORSE POWER, HITCH, CONNECTOR, ACCESSORIES	13	115-117
LUBRICATION & MAINTENANCE: LUBRICATION & MAINTENANCE CHART, EXTERIOR, INTERIOR	14	121-126
SPECIFICATIONS: EXTERIOR DETAILS, CAPACITIES, BULB REPLACEMENT	15	129-132
INDEX:		137-138

NOTE: Please refer to page 133 for any improvements made in your trailer after this manual was printed.

TABLE OF CONTENTS



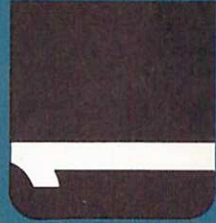

WALLY BYAM CARAVAN AND CLUBS

THE UNIVERSITY OF CHICAGO

[The remainder of the page contains extremely faint and illegible text, likely bleed-through from the reverse side of the document.]



The late Wally Byam, Pioneer trailer traveller, founder of Airstream Inc.

You are now an Airstream owner. The magic doors to fun, friendship and adventure are wide open to you ...and the rich rewards are endless. You are now eligible to take part in all Wally Byam Caravans and Airstream Rallies. There are four rallies held annually: one in the North West, South West, North East, and South East, and folks look forward to them with eager anticipation.

As an Airstream owner, you are also eligible to make an application for membership into the Wally Byam Caravan Club International — the largest and most influential travel trailer club in the world. There are WBCC units throughout the United States, five in Canada, and one in Mexico. All operate autonomously, electing their own officers and setting their own dues. All new members are required to join through a local unit. (Legislation was adopted in 1962 stating that members-at-large would no longer be accepted.) At the time your application is made, International dues are paid along with Unit dues. At present, International dues are \$3.00 per year per trailer. Unit dues average from \$1.00 to \$5.00.

Some units get together for monthly rallies while some have weekly Dutch-treat dinners in addition to their regular rallies. In areas where weather does not permit year-round rallies, the dinner meetings are very popular. They give members a wonderful opportunity to keep in touch and to plan events for the more seasonable times of the year. International, Regional and Unit Officers are elected annually. If you are interested in joining the Wally Byam Caravan Club

International, get in touch with the secretary in your area. The name of each secretary is listed in the Headquarters Office (15939 Piuma Ave., Cerritos, California 90701) and your letter will be forwarded.

The first Wally Byam Caravan was in 1951. Since then there have been 57 caravans to most parts of the world. The annual caravans to Canada and Mexico have become so popular that in recent years we have conducted two caravans each year to these neighboring countries.

Traveling with a Wally Byam Caravan teaches you how to travel in a foreign country as well as how to get the most enjoyment out of your Airstream. You travel with both old and new Airstream owners — sharing experiences, learning from one another and enjoying a new kind of fellowship. On the caravans and in the club, you will make life-long friends, friends who become closer and dearer to you than many you have known all your life. As Wally used to say: "You will never be alone or lonely."

Traveling with the caravan offers many advantages; the security of group travel, recognition, and unusual opportunities to see special places and meet special people. Many of these opportunities, which would never be possible for individuals, are routine for the caravan. The blue beret,





the badge of Airstream ownership and identification for a Wally Byam Caravanner and Club member, is an open sesame to excitement and adventure.

Several months before a caravan rolls, it is announced in the CARAVANNER and the BLUE BERET (the club's official monthly publication), a registration coupon is printed for your convenience, and everyone who registers receives a detailed bulletin telling about that particular caravan, what to bring along and how to prepare for it. When going to Mexico and Central America, such matters as insurance, tourist cards and other details connected with border crossings are all handled for you by the Caravan Staff. When you go on a high adventure caravan such as one to Europe, Africa or around the world, all details are also taken care of for you. About all you have to do is get your passport and take your shots. Those are two items we cannot do for you — or we would.

On every Airstream Wally Byam Caravan, the route is carefully planned and arrangements are made for parking, entertainment, tours, etc., long before the caravan ever leaves. A day-by-day itinerary is planned and a copy indicating the mail stops is given to all Caravanners in advance.

Although Airstream provides a caravan team consisting of a leader, recreation leader, advance representative, and service representative, the caravan is actually run by committees made up of the caravan members themselves. The Airstream Wally Byam Caravans are a family affair. Everyone participates and becomes a part of the great Airstream family. Each is an unforgettable experience.

Only Wally Byam Caravanners and WBCC members are entitled to the official caravan numbers, and to be listed

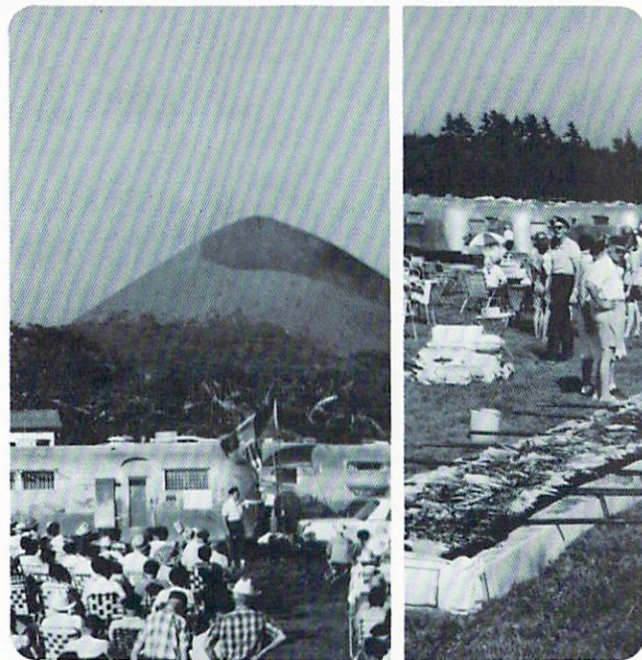

in the annual directory. Club members receive their number from the Headquarters Office. The Caravanners who are not club members receive their numbers at the rendezvous point before the caravan leaves.

The annual directory lists all WBCC members and Wally Byam Caravanners including names of those who have parking space available at home for fellow Airstream owners. It's really wonderful to be able to pull into the yard of a friend (even if you have never met) rather than have to hunt for a trailer park. The directory also lists a schedule of all major rallies for the year, all WBCC Amateur Radio Club (hams) C.B. Radio Club, and a list of Wally Byam Caravans.

Rallies held toward the end of June and the first week of July every year. Wally's birthday was July 4, and the first Rally was in the form of a huge birthday party for him, patterned after the International Rallies in Europe which he loved to attend. Until 1956, when the first Wally Byam Caravan attended the rally in Perpignon, France, Wally and his wife Stella had been the only Americans present. Everyone had such a good time at this first big get-together held in the beautiful Ozarks that the club decided to make it an annual affair. Since then International Rallies have grown tremendously in size and scope. A recent International Rally at Cadillac, Michigan brought together more than 2,828 Airstreams and some 10,000 happy people. The site of the International Rally for the summer is announced in an early fall issue of the CARAVANNER and the BLUE BERET.

In all our caravan and club activities, the program is planned for all ages — from babies in arms to those in

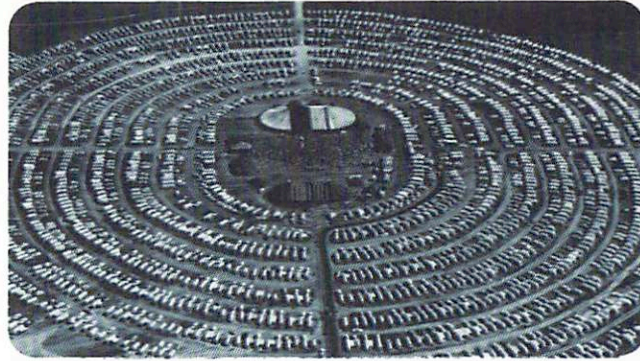

their nineties — but you would never guess that anyone was in the 90-year bracket.

Within the WBCC are square dance clubs, past presidents clubs, Citizen Band radio clubs, the ARCs (hams), special study groups, hiking and bird-watching groups, avid fishermen and boating enthusiasts. And many other groups like the "FREE WHEELERS."

Along with the fun, our Airstream owners recognize the need for better legislation regarding travel trailers; more overnight parking places, more sanitary stations for emptying waste-holding tanks, etc. They're also quite alert to bills adverse to travel trailers. In this field, the WBCC has a strong National Legislative Committee, and we are justly proud of their accomplishments.

When you bought your Airstream, you not only bought the prestige travel trailer in America, but truly a whole new way of life. Enjoy it! Many new friends are waiting to be found . . . new adventures are waiting to be discovered. We are happy to welcome you into our Airstream family.

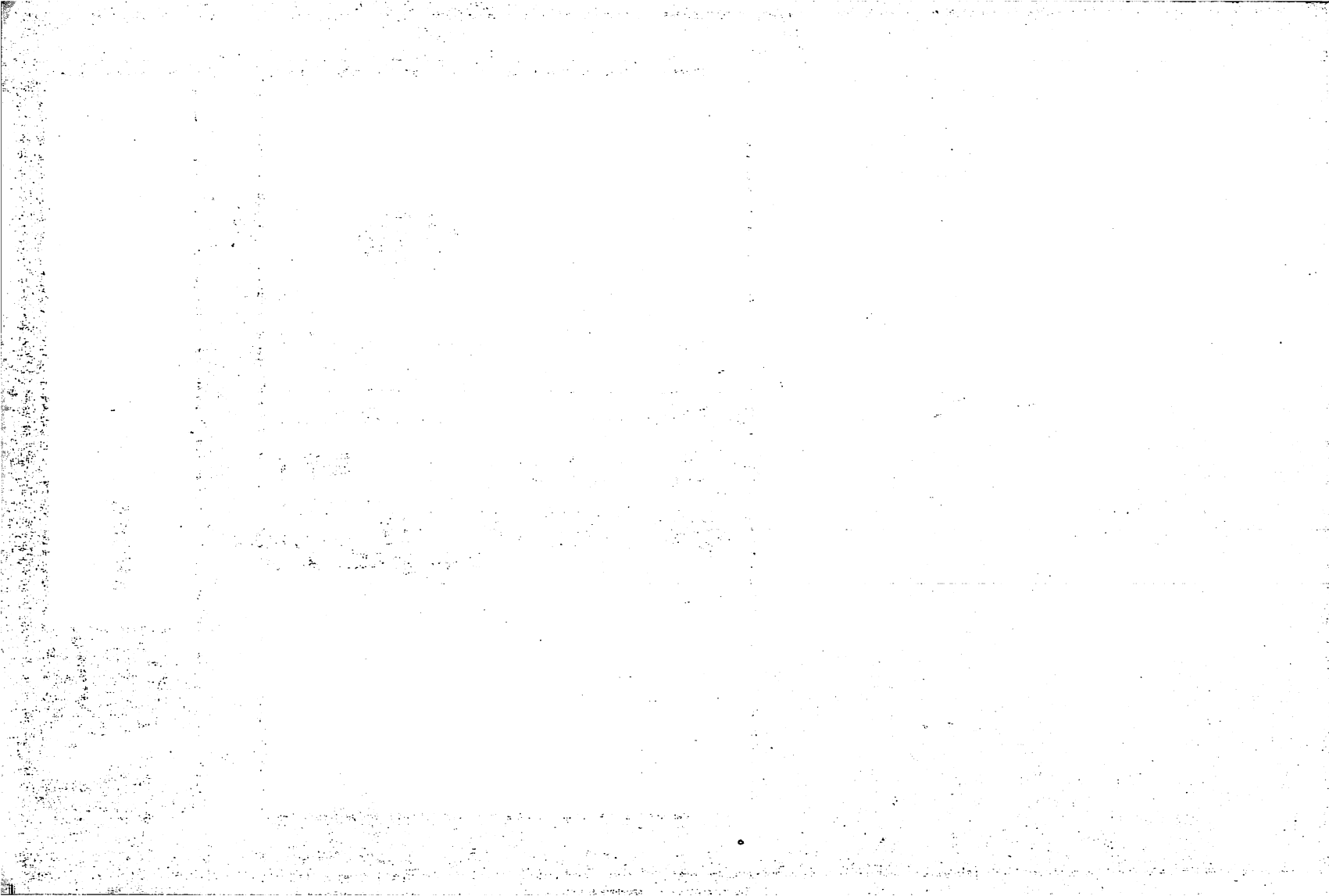

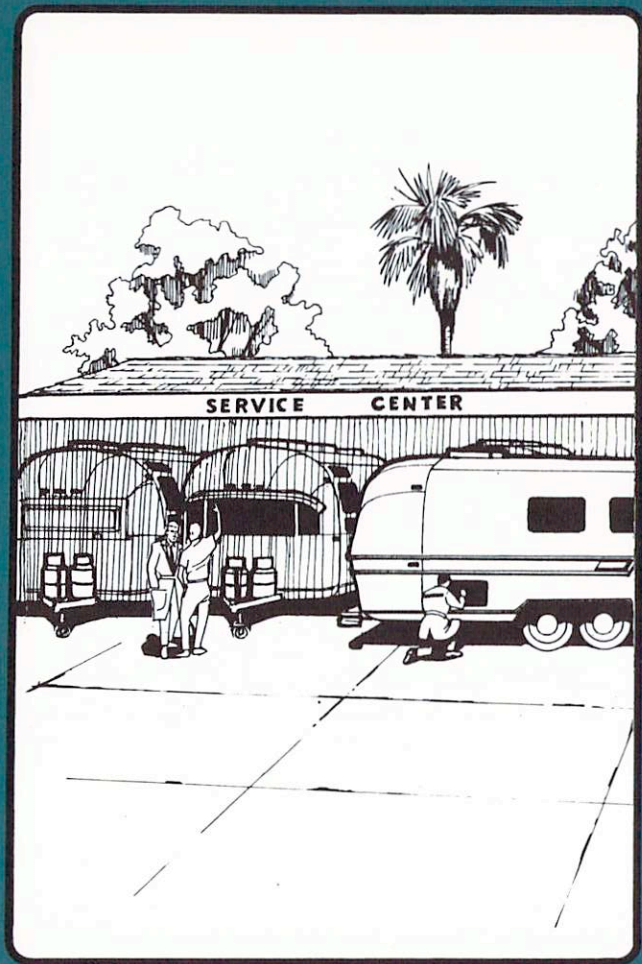

SERVICE

2

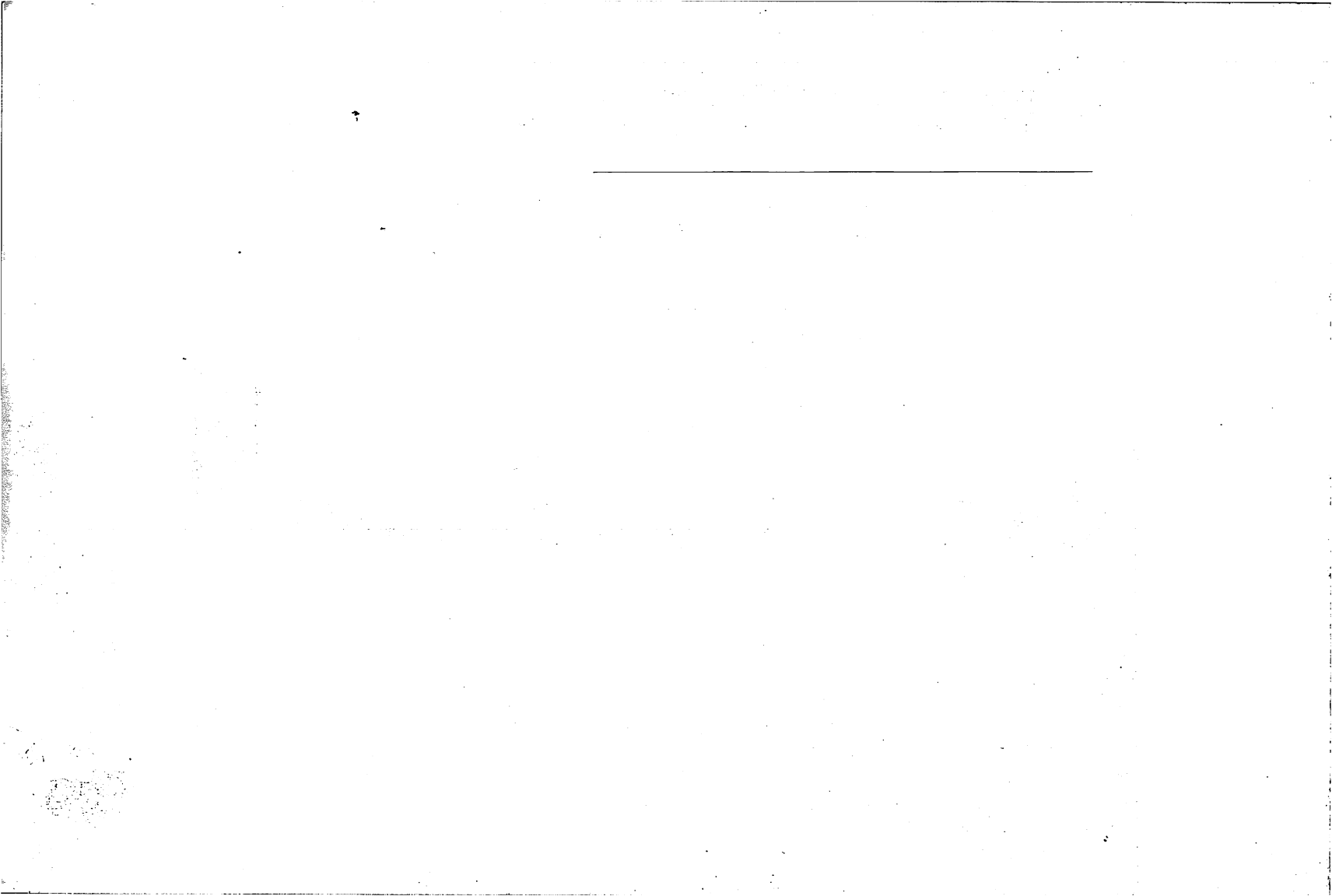



AIRSTREAM WARRANTY



For the lifetime of the Registered Warranty Holder, or so long as he continues as the original owner of the Airstream Travel Trailer, Airstream warrants the metal shell, frame, axle and axle assembly to and including spindle (excluding shock absorbers) to be free from defects in material and workmanship; all other component parts, including shock absorbers (excluding tires and batteries) are likewise warranted for a period of two years from the date of purchase. Any warranty defects will be corrected without cost upon return of the trailer, or defective part, to any Airstream factory or authorized Airstream service center.

This warranty is in lieu of all other warranties of merchantability or fitness expressed or implied, there being no warranties which extend beyond the description on the face hereof and expressly excludes conditions resulting from normal wear, accident, abuse, exposure or overload.

AIRSTREAM

Ohio factory: 177 West Church Street, Jackson Center, Ohio 45334

California factory: 15939 Piuma Avenue, Cerritos, California 90701



AIRSTREAM WARRANTY



As an Airstream owner, you are privileged to the most complete and explicit warranty made by any manufacturer in the industry. You are specifically requested to read this reproduction of the warranty before signing your customer check-out and acceptance sheet upon delivery of your new Airstream. As soon as the factory has received your signed check-out sheet, your Airstream warranty will go into effect . . . a formal warranty will be issued to you . . . and an owner's identification card will be sent you so that you may receive warranty work without charge from Airstream Certified Service Center dealers. When you receive your formal warranty remove and destroy this facsimile, then put formal warranty inside front cover of this manual.

CAUTION: You must register within 30 days of purchase of your Airstream to be eligible for the Airstream warranty.

CERTIFIED PERFORMANCE CHECKOUT

The Airstream Certified Performance Check-out . . . or C.P.C. . . . is an exclusive Airstream program tailored in an attempt to maximize your opportunity for complete satisfaction with your new Airstream. Before leaving the factory, each and every vital part of an Airstream is tested for performance. Each test is signed and certified by an inspector. After the Airstream arrives on your dealer's lot, all of these vital parts and systems are tested and certified once more. Then when you take delivery of your new Airstream, a factory-trained trailer expert personally gives you a complete check-out on the trailer.

But C.P.C. doesn't stop here. After you have traveled with your Airstream for 1000 miles (or 60 days) whichever occurs first, you can make an appointment with any one of the 175 Airstream dealers in every state of the union for still another thorough going over of your trailer. At that time, a specified list of performance checks on your trailer equipment and systems will be conducted by your dealer as well as remedial care for any deficiencies you have experienced in use. The attached card is your authority for this check.

AIRSTREAM WARRANTY.

As an Airstream owner, you are privileged to the most complete and explicit warranty made by any manufacturer in the industry. You are specifically requested to read the reproduction of the warranty before signing your customer check-out and acceptance sheet upon delivery of your new Airstream. As soon as the factory has received your signed check-out sheet, your Airstream warranty will go into effect . . . a formal warranty will be issued to you . . . and an owner's identification card will be sent you so that you may receive warranty work without charge from Airstream Certified Service Center dealers. When you receive your formal warranty remove and destroy this facsimile, then put formal warranty inside front cover of this manual.

Please note that your warranty will not be in effect until it is registered, and that Airstream Factory Authorized Certified Service Centers are not authorized to provide service under the Lifetime Warranty unless your I.D. card or registered warranty can be produced at the time the service is performed. If and when the occasion arises that you require service on your trailer, we suggest that you contact your dealer. If the service is minor, or simply involves an adjustment, he will perform the service. Should you require service on one of the appliances, he may suggest you contact one of the service and repair depots provided for each appliance. These depots will provide service under their respective warranties. For major service under your Airstream Warranty, we have established a nationwide network of Factory Authorized Certified Centers, staffed with factory-trained service specialists. For prompt service simply present your Airstream Lifetime Warranty or I.D. card to any of the Factory Authorized Certified Service Centers listed

SERVICE



on the following pages.

Of course each Airstream plant maintains a very complete service department to take care of your major service needs. But in order to expedite customer service, it is necessary that these service departments be operated on a scheduled appointment basis.

Please communicate with the Service Manager as to when you intend to visit the factory, and request an appointment for service. It is essential also to advise the Service Managers when you are unable to meet the appointment date.

**Service Manager Airstream, Inc.
Jackson Center, Ohio 45334
(513) 596-6129**

**Service Manager Airstream, Inc.
15939 Piuma Ave.
Cerritos, Calif. 90701
(213) 868-3748**



ALABAMA

Camper City & Mobile Home Sales
7302 First Avenue, North
Birmingham, Alabama 35200

ARIZONA

Robert Crist & Company
1665 East Main Street
Mesa, Arizona 85201

Ravan Mobile Homes, Inc.
3528 North Oracle Road
Tucson, Arizona 85705

ARKANSAS

Fred & Jack Trailer Sales
6600 Asher Avenue
Little Rock, Arkansas 72204

CALIFORNIA

Bonanza Trailer Sales
636 South 9th Street
Modesto, California 95351

Caswell Trailer Sales
950 West Foothill Boulevard
Claremont, California 91711

Central Valley Trailer Center
333 West Fresno Street
Fowler, California 93625

Coastline Trailer Sales
303 North Ventura Avenue
Ventura, California 93001

El Camino Trailer Sales
2090 El Camino Real
Mountain View, California 94040

Mitchell Motor & Trailer Sales
5690 Redwood Highway, North
P.O. Box 1495
Santa Rosa, California 95404

Valley Trailer Sales
2446 Rio Linda Boulevard
North Sacramento, Calif. 95815

COLORADO

Chisman Trailer Sales
2501 East Boulder Street
Colorado Springs, Colo. 80909

Denver Trailer Sales
11200 West Highway 6
P.O. Box 15066
Lakewood, Colorado 80215

CONNECTICUT

Wepawaug Trailers, Inc.
655 Bridgeport Avenue
Milford, Connecticut 06463

DELAWARE

Richard Rice, Inc.
601 South Dual Highway
Seaford, Delaware 19973

FLORIDA

Bell's Trailer Park & Sales
R.R. #4, Box 382
Highway 90, West
Tallahassee, Florida 32301

Cribbs' Campers
5408 San Juan Ave.
Jacksonville, Florida 32210

Indian River Trailer Sales
U.S. 1
Cocoa, Florida 32922

Jerry's Trailer Sales & Service
2710 North West 36th Street
Miami, Florida 33142

C. J. Stoll, Inc.
5985 — 34th Street, North
U.S. 19
St. Petersburg, Florida 33714

C. J. Stoll, Inc.
825 U.S. 301, Blvd. East
Bradenton, Florida 33505

GEORGIA

C & M Vacation Trailers
Rt. #1, Box 317
9726 South of Atlanta
Jonesboro, Georgia 30236

ILLINOIS

Deluxe Mobile Home Sales, Inc.
2800 West Farmington Road
Peoria, Illinois 61604

Hunter Motors, Inc.
415 North Illinois Avenue
Carbondale, Illinois 62901

Mann's Trailer Sales
R.R. #1, North Normal, U.S. 51
Normal, Illinois 61761

Ray's Travel Trailer Sales, Inc.
7135 — 49 West Irving Park Rd.
Chicago, Illinois 60634

Robert Crist & Company
9100 South Stony Island Avenue
Chicago, Illinois 60617

Ted Christman Auto Sales
202-4 North Vine Street
Urbana, Illinois 61801

INDIANA

Berning Trailer Sales
5220 New Haven Avenue
Fort Wayne, Indiana 46803

Bert's Trailer Sales, Inc.
R.R. #3, Box 17 (East U.S. 20)
Michigan City, Indiana 46361

Bill's Trailerland Sales & Serv. Ctr.
12th & Main Street
Vincennes, Indiana 47591

Draper's Auto Trailer Sales, Inc.
912 State Road 67 East
Anderson, Indiana 46012

Eberhart Trailer Park & Sales, Inc.
541 East Hendricks
Shelbyville, Indiana 46176

IOWA

Ace Fogdall, Inc.
Highway 218 at Rownd Street
Cedar Falls, Iowa 50613

Bill Brown Trailer Sales
3700-3708 East 14th Street
Des Moines, Iowa 50313

KANSAS

Boulevard Motor & Trailer Co.
5617 West Kellogg
Wichita, Kansas 67209

KENTUCKY

Murphy Sales Company
Benson Road
Shelbyville, Kentucky 40065

Murphy Sales Company
Winchester Road (U.S. 60 W)
Mt. Sterling, Kentucky 40353

LOUISIANA

Barrow's Inc.
7517 Chef Menteur Highway
New Orleans, Louisiana 70126

MASSACHUSETTS

Mosher Travel Trailer Center, Inc.
Blue Jay 4 Corners
Sutton, Massachusetts 01527

MICHIGAN

Bob Frank Trailer Sales, Inc.
1416 West Columbia
Battle Creek, Michigan 49015

Frontier Camping Post
11111 S. Telegraph at Goddard
Taylor, Michigan 48180

Kolbe Trailer Sales
5785 East Eight Mile Road
Warren (Detroit), Mich. 48091

Mid-State Trailer Sales
5103 Eastman Road
1/2 mi. South of 1 — 75 on U.S. 10
Midland, Michigan 48640

Northwoods Trailer Sales
G-6369 North Dort Highway
Mt. Morris, Michigan 48458

Warner Trailer Sales, Inc.
3098 West Huron Street
Pontiac, Michigan 48054

Woodland Travel Center, Inc.
5190 Plainfield Road
Grand Rapids, Michigan 49505

MINNESOTA

Phil Dunning Trailer Sales, Inc.
3050 Coon Rapids Boulevard
Coon Rapids, Minnesota 55433

certified service centers

SERVICE



Hart Trailer Sales
Highway 71
Long Prairie, Minnesota 56347

Pioneer Trailer Sales
Highway 218, South
Austin, Minnesota 55912

MISSOURI

Bill Thomas Camper Sales
5217 North Lindberg Boulevard
St. Louis (Bridgeton), Missouri
63044

Kansas City Trailer Sales, Inc.
14815 South 71 Highway
Grandview, Missouri 64030

MONTANA

Oliver Trailer Sales
5124 Laurel Road
Billings, Montana 59101

NEBRASKA

A. C. Nelsen Company
2112 Harney Street
Omaha, Nebraska 68102

NEVADA

"95" Trailer Sales
4339 Tonopah Highway
Las Vegas, Nevada 89106

NEW JERSEY

**South Jersey Travel
Trailer Center, Inc.**
Route 47
Franklinville, New Jersey 08322

NEW MEXICO

Gunns Travel Trailers
7707 Menaul Boulevard, N.E.
Albuquerque, New Mexico 87110

NEW YORK

Atlantic Trailer Sales
1226 Fairport Road
Fairport, New York 14450

Belaire Trailer Sales, Inc.
P.O. Box 55
1 mile North on Route 11
North Syracuse, New York 13212

Callahan's Trailer Sales
R.R. #1, Route 15
Lindley, New York 14850

Carson Rotary Service
321 Bridge Street
Vestal, New York 13850

**Maroone Family
Travel Center, Inc.**
2550 Walden Avenue
Exit 52, East of N.Y. Thruway
Buffalo, New York 14225

Niblack Trailer Sales
691 McLean Avenue
Corner N.Y. Thruway
Yonkers, New York 10704

O'Malley Enterprises, Inc.
P.O. Box 116
Traffic Circle, Rts. 9 & 7
Latham, New York 12110

NORTH CAROLINA

College Park
North Church Street Ext.
US 301 & 301A, North
Rocky Mount, N.C. 27803

Faires, Inc.
P.O. Box 5205—Routes 29 & 49
Charlotte, North Carolina 28206

Out of Doors Mart
3686 Reynolda Road — Rt. 67 N.
Winston-Salem, N. C. 27106

OHIO

Frank B. Ricketts Mobile Homes
Travel Trailers
Box 583
Clark Street and Maple Road
Cambridge, Ohio 43725

K & B Airstream Sales
8641 Mentor Avenue
Mentor, Ohio 44060

Louisville Trailer Sales
1001 West Main Street
Louisville, Ohio 44641

Macke Trailer Sales & Rental
1044-1110 East Spring Street
St. Marys, Ohio 45885

Marine Mart Trailer Sales
8750 Harrisburg Pike
16 miles S.W. Columbus
on US 62
Harrisburg, Ohio 43126

Murphy Sales Company
11526 Chester Road
1-75 at Howard Johnson
Cincinnati, Ohio 45216

P-J Airstream Sales, Inc.
5247 Alexis Road
Sylvania, Ohio 43560

Richland Travel Trailers
302 Ashland Road
Mansfield, Ohio 44905

**Sommer's
Mobile Home Sales, Inc.**
U.S. 57 at Turnpike, Exit 8
1800 Lorain Boulevard
Elyria, Ohio 44035

State Trailer Sales,
1715 North State Street
Girard, Ohio 44420

OKLAHOMA

Brassfield Mobilhomes
7207 N.W. 39th Expressway
Bethany, Oklahoma 73008

Jack Thurman
11311 East Admiral Place
Tulsa, Oklahoma 74116

OREGON

Cascade-Pacific Trailer Sales
1876 Highway 99 North
Eugene, Oregon 97402

Spencer Mobile Homes
9341 S.E. 82nd Avenue
Portland, Oregon 97266

PENNSYLVANIA

Farnsworth Camping Center
Route 54
Elysburg, Pennsylvania 17824

Turner Airstream Sales
412 Lincoln Highway, West
Jeannette, Pennsylvania 15644

Walter A. Glasgow
1650 Lincoln Way West
Chambersburg, Pa. 17201

SOUTH CAROLINA

Dixie Lee Drive Inn & Trailer Sales
Highways U.S. 1 & 78
5 miles N. of Augusta, Georgia
Bath, South Carolina 29816
Mail: Box 306
Clearwater, South Carolina 29822

Skyway Mobile Homes
Box 262
U.S. 25 at 276, 4 miles N.
of Greenville
Travelers Rest,
South Carolina 29690

SOUTH DAKOTA

Capital City Trailer Sales
801 North Euclid Avenue
Post Office Box 116
Pierre, South Dakota 57501

TENNESSEE

**Cullum & Maxey
Sales & Servicenter**
160 McGavock Pike
Donelson (Nashville),
Tennessee 37214

Campers Inc.
1401 Central Avenue, North
P.O. Box 358
Knoxville, Tennessee 37917

TEXAS

Abbott Trailer Sales
408 Avenue Q
Lubbock, Texas 79401

Baker Travel Trailers
4200 East Belknap
Fort Worth, Texas 76117

Land Yacht Trailer Sales
4616 Titanic Avenue
El Paso, Texas 79904

L & H Trailer Sales
611 North Fisk Avenue
Post Office Box 1168
Brownwood, Texas 76801

Lloyd's Trailer Sales Inc.
350 Twin City Highway
Port Neches, Texas 77651

Mission Mobile Homes
1306 Austin Highway
San Antonio, Texas 78209

South Texas Trailers & Supplies
Highway 77, South
P.O. Box 1051
Sinton, Texas 78387

Sportsman Travel Trailer, Inc.
7935 Gulf Freeway, Exit 12
Houston, Texas 77017

**Texas Trailercoach of
Dallas, Inc.**
2929 Fort Worth Avenue
Dallas, Texas 75211

**Wallace Land Yacht
Sales & Service**
2005 Mangum
Houston, Texas 77018

UTAH

Intermountain Trailer Sales
3776 Wall Avenue
P.O. Box 1503
Ogden, Utah 84401

VERMONT

Pete's Trailer Mart
4016 Williston Road
South Burlington, Vermont 05401

VIRGINIA

Travel Trailers of Virginia
P.O. Box 807
2211 South Main Street
Harrisonburg, Virginia 22801

McGeorge Travel Center
6200 W. Broad St.
Richmond, Virginia 23230

WASHINGTON

Birch Bay Trailer Park & Sales
Route 1, Box 106
On Birch Bay
Blaine, Washington 98230

Central Trailer Exchange, Inc.
14433 Pacific Highway, South
Seattle, Washington 98168

Comrie Trailer Sales
309 N. Fruitland Avenue
Kennewick, Washington 99336

Tveten Motor Company
45th & Pacific Avenues
Tacoma, Washington 98408

WEST VIRGINIA

Don's Travel Trailers
459 Winfield Road
U.S. 60 at 17
St. Albans, West Virginia 25177

WISCONSIN

J & M Homes
1360 Velp Avenue
Green Bay, Wisconsin 54303

Northside Trailer Sales
N56 W13180 W.
Silver Spring Road
1 mi. W. of Hwy. 100 on
Silver Spring Road
Menomonee Falls,
Wisconsin 53051

Swee Trailer Sales
U.S. 51 and U.S. 2
Hurley, Wisconsin 54534

Trailerama of Sparta
West Wisconsin Avenue
Highway 16
Sparta, Wisconsin 54656

Wisconsin Mobile Homes, Inc.
4201 East Washington Ave.
Madison, Wisconsin 54704

CANADA

Butcher & Son, Ltd.
P.O. Box 693
Trans Canada Highway, East
Brandon, Manitoba, Canada

Dyke's Caravans
St. Luc (Rts. 7 & 9B)
CO St. Jean, Quebec, Canada

Totem Trailer Sales, Ltd.
85 Plains Road West
Burlington, Ontario, Canada

**Propane Engineering
Service Center**
2301 Centre Street North
Calgary, Alberta, Canada

certified service centers

SERVICE



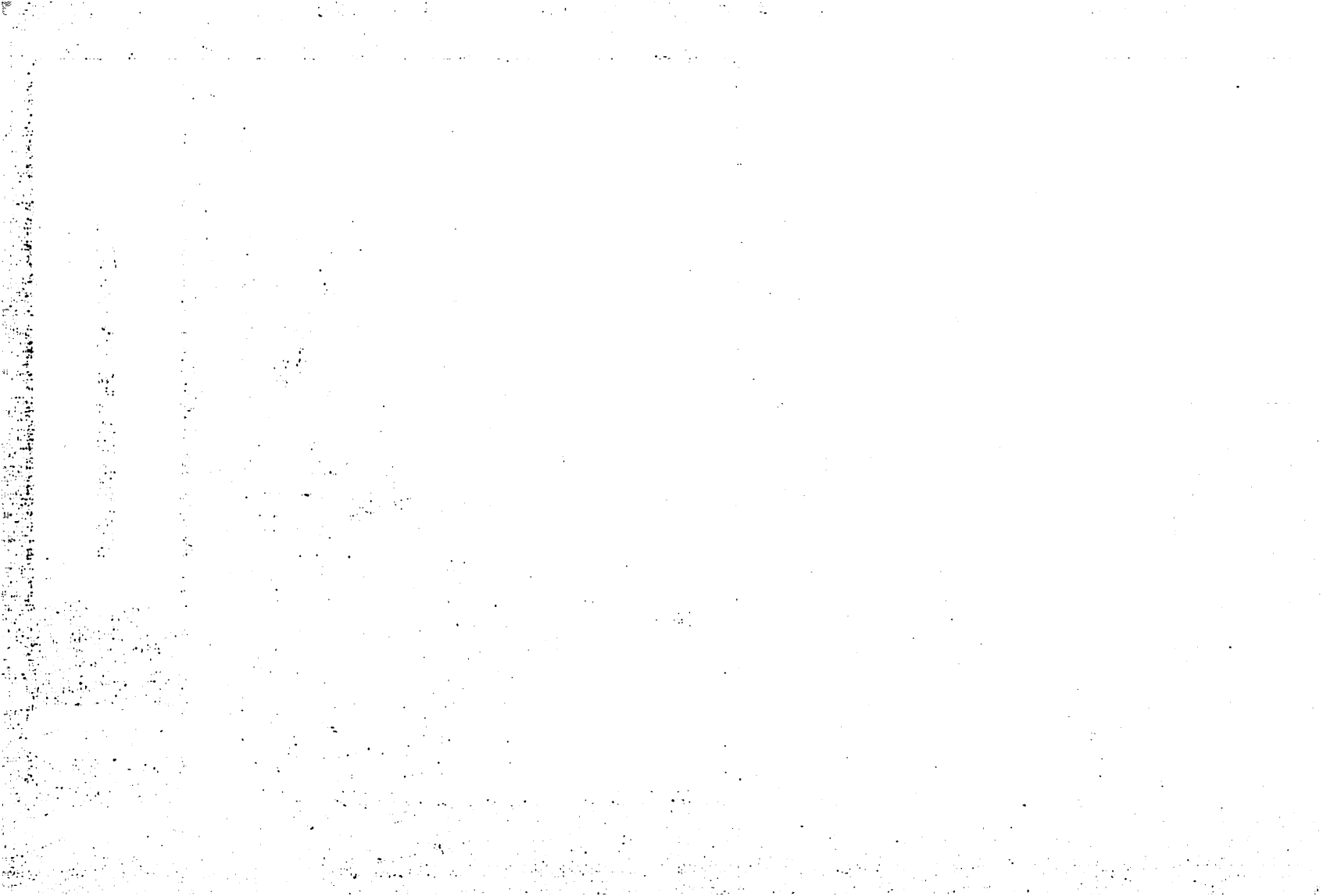

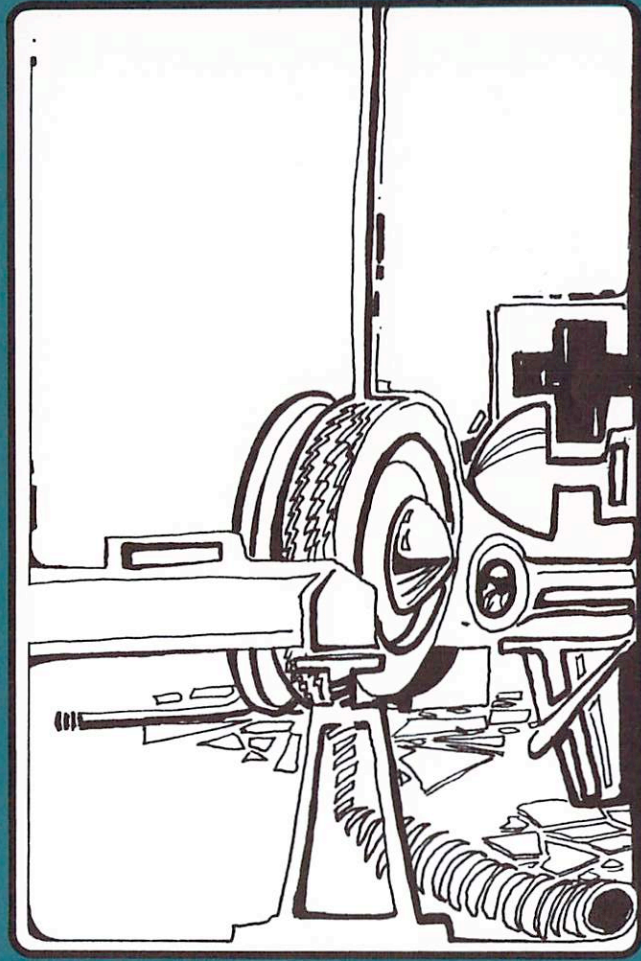

3

EQUIPPING TRAILER FOR THE ROAD



There are as many accessories and appliances for your Airstream as there are for any home. Your Airstream dealer will be able to help you select those accessories you will need, depending on where you wish to travel and for how long.

OUTFITTING YOUR TRAILER.

Outfitting your Airstream, that is, converting the bare vehicle you bought from the dealer into a comfortable home, is very similar to outfitting any home or apartment. Your Airstream is completely furnished, but there are many little personal touches you will want to add. Since your Airstream will be subject to the vibrations and bumps of the road, anything that is attached should be done so firmly. A small hand drill should be used to drill holes in the aluminum inner walls and one-half inch No. 8 sheet metal screws, with flat binder heads, used to attach such things as hooks for clothing, book shelves, extra towel racks, those little accessories you "can't do without."

EQUIPMENT YOU SHOULD CARRY

1. A first aid kit.
2. A tool box with an assortment of small hand tools such as screwdrivers, pliers, wrenches, etc.
3. A tow rope: $\frac{3}{4}$ " to 1" nylon is sufficient — at least 35 feet is recommended.
4. A lug wrench to fit your trailer wheel lugs.
5. A hydraulic jack for your trailer axle.
6. Two stabilizing jacks. Two additional stabilizing jacks are recommended for the front of the trailer if you frequently stop for several days at a time.

7. A spare tire for your trailer.
8. A fire extinguisher.
9. Plastic buckets for carrying water (at least two).
10. Wheel blocks — these should be 4 blocks of wood, approximately 7" square and 4" thick, slanted at one end to fit against the tire, to block the wheels when parked.
11. A hundred feet of $\frac{5}{8}$ " water hose — (A "Y" connection is useful when you travel with others since it permits two trailers to be hooked together on one faucet).
12. 1 short (4-foot) and 1 long (10-foot) sewer hose and a coupler.
13. A 75-foot 3-wire electric cord with a 30-amp capacity, with grounding-type 3-prong plug and receptacle to match cord on Airstream.
14. A small spirit level (two will be helpful).
15. A flashlight.
16. A short handle shovel (the Army surplus G.I. type is satisfactory).
17. A pick or pry bar.
18. An axe.
19. A five gallon gasoline can.
20. A large funnel.
21. A folding chair for each person.
22. Cleaning equipment: Broom, dust pan, mop, bucket, sponges, etc.
23. Road emergency flares.
24. Spare cartridge-type 40-amp fuses.
25. A "Jerry Can" or other suitable portable water container (approx. 5 gal.).

Most of the above items are available through Wally Byam Stores.

outfitting trailer
equipment list

EQUIPPING TRAILER
FOR THE ROAD





ACCESSORIES FOR TRAILER (Optional)

RADIO AND TELEVISION.

Since the aircraft-type aluminum construction of your Airstream makes an almost perfect radio "shield" you will need outside antennas for good reception of either radio or television.

Your new Airstream is wired for an exterior television antenna. To install the antenna it is recommended that you go to our Airstream dealer since it must be structurally mounted and sealed to the trailer. The interior antenna jack will be found adjacent to the electrical outlet forward of the galley on the road side. This has been located in the most convenient spot for TV viewing in your particular model. This TV antenna is available through the Wally Byam Stores or your dealer, and is specially designed for the Airstream trailer.

A police-type telescoping whip radio antenna is recommended particularly for 12-volt transistor AM-FM radio use. This should be installed on the front of your trailer on the road side next to the front window on a swivel ball mount by an authorized dealer.

AIR CONDITIONING.

The Airstream Bay Breeze air conditioner is specially designed to keep your trailer cool and comfortable in the hottest weather. Since the Bay Breeze requires certain modifications in your trailer, it should only be installed by one of the many Airstream dealers who are equipped for this type of service or at one of the Airstream factories.

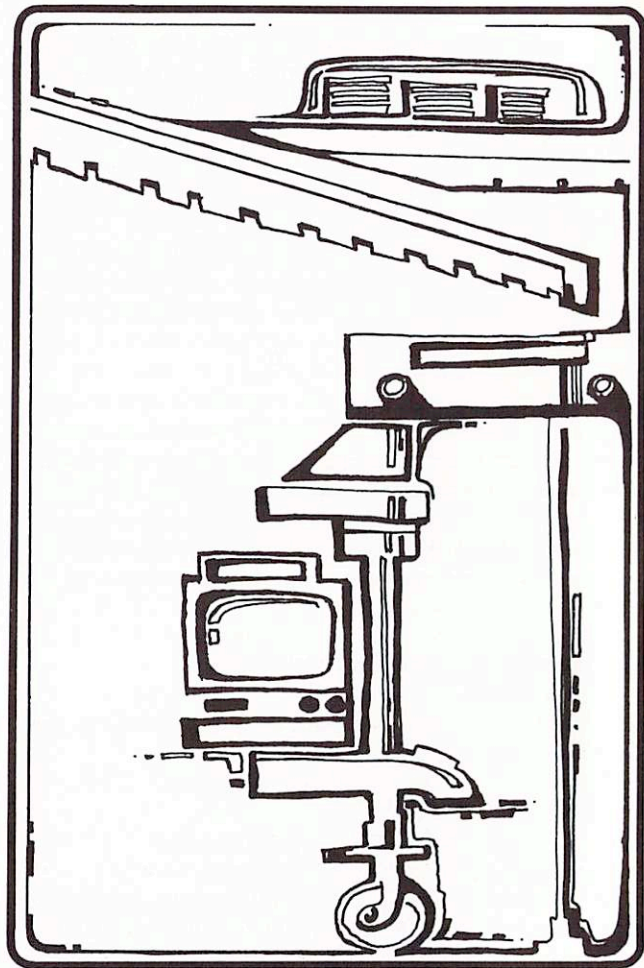

VISTAVIEW WINDOWS.

The optional vistaview windows (non-opening) are an exclusive Airstream feature. These skylight type windows come equipped with an integral jet-liner type shade so that they may be completely closed off when desired. They are especially nice in heavily wooded campsites, early morning, late evenings, on dark days, or whenever additional outside light is desired. They are also useful for letting in light even though you wish the drapes to remain closed for privacy.

AWNING.

For use while attending rallies or for a nice place to sit in the shade. Wherever you park you'll find the easy operating "instant shade" awning to your liking. This patio cover is available through Wally Byam Stores and can be installed very quickly and easily by your dealer.

ELECTRIC HITCH JACK.

The electric jack is strongly recommended for anyone who, for any reason, should not physically exert himself. Available as a factory option or through the Wally Byam Stores, the electric jack makes hitching and unhitching a much easier operation, even for the wife. It's strong enough to lift the rear end of most cars and can be an aid in changing flat tires.

AUXILIARY STEP EXTENSION.

This handy extra step slips into place easily into the standard fold away step to provide easier entrance and exit. This step is especially useful when the terrain requires the trailer hitch to be raised quite high in order to level the trailer, a condition which is quite common.

BUNKS.

For added sleeping space, fold-away bunks can be installed over twin or double beds, or side pull-out (gaucho) beds. They may also be installed crossways over the front lounge. Mattresses are optional with these bunk beds, but for maximum comfort, we would recommend their use. Each bunk is furnished with storage brackets to provide out of the way storage when the bunk is not in use. Bunks can be installed by your dealer anytime you feel the need for more sleeping space.

In addition to the above, you will find many other accessories to make your trailering more enjoyable, available at Wally Byam Stores and your dealer. As you travel you will develop your outfit to suit your particular needs.

accessories

EQUIPPING TRAILER
FOR THE ROAD



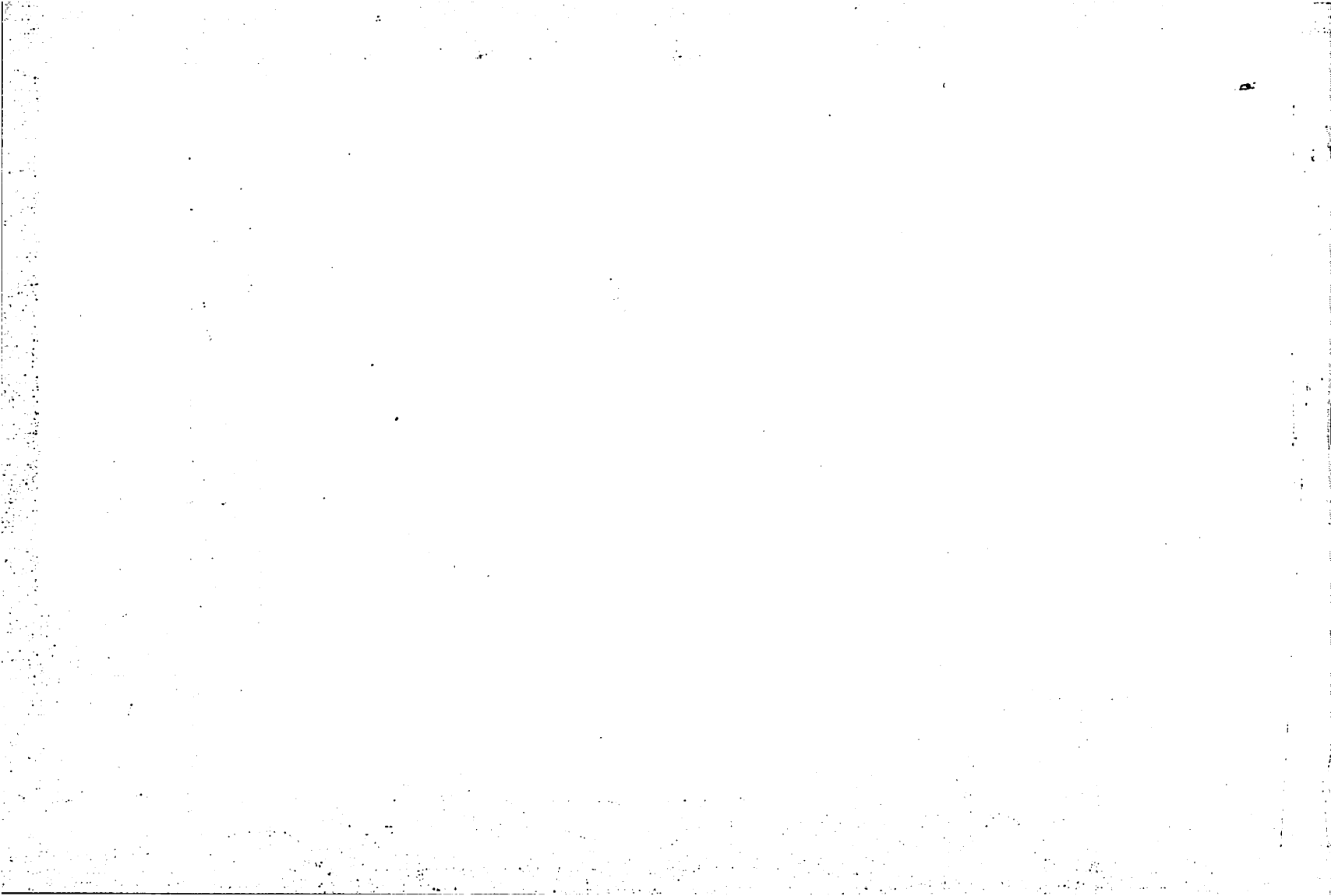

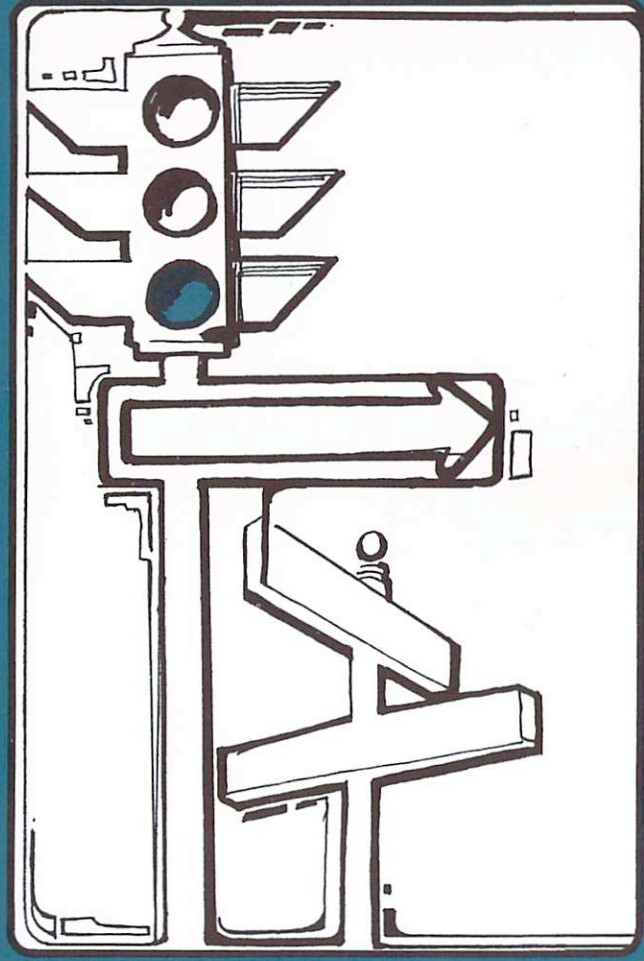

TOWING TIPS

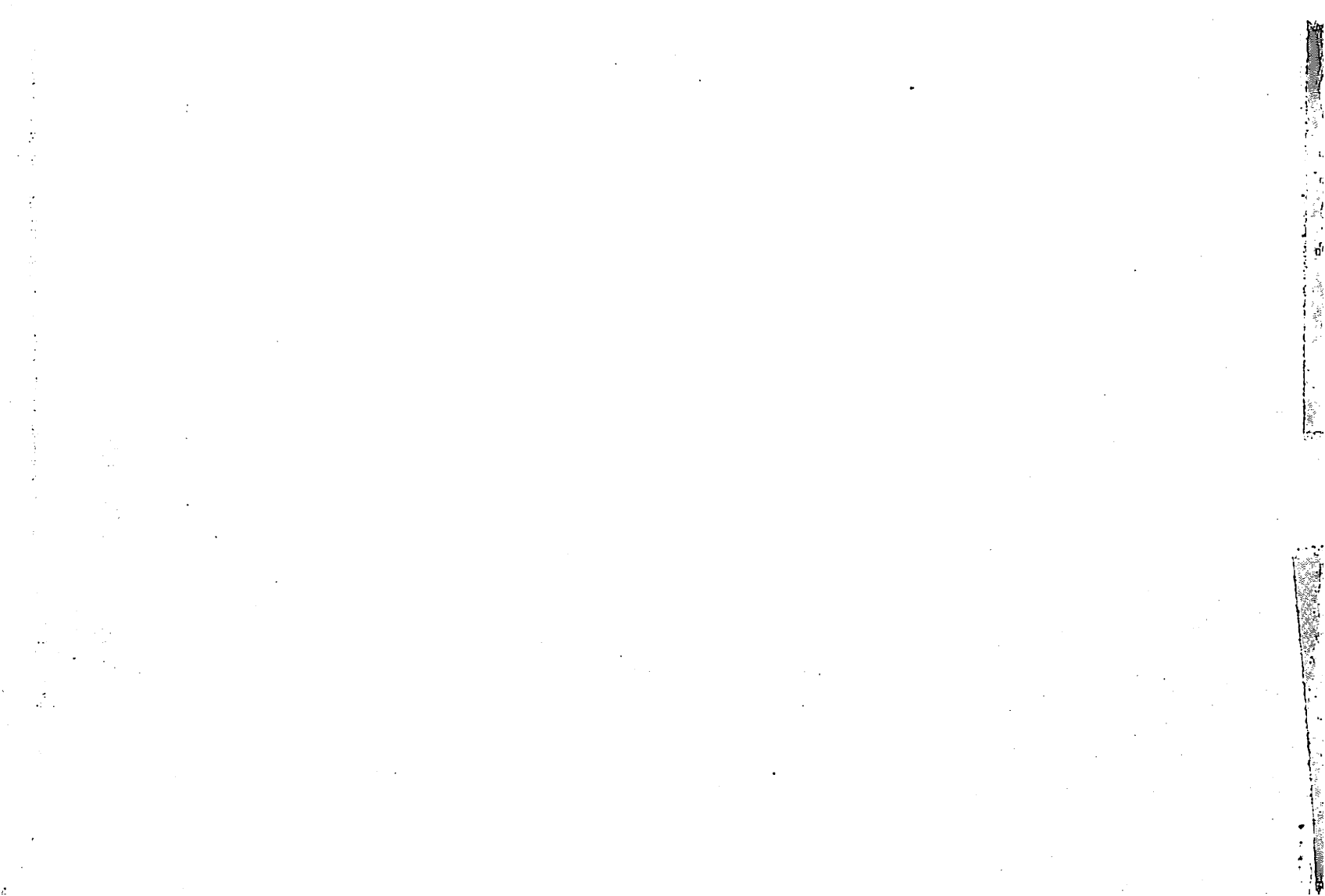

HITCHING UP.

In most cases by the time you read this manual you will already have a hitch installed on your towing vehicle. In any case we recommend you read in chapter 13 the information on the different types of hitches and their proper installation and adjustments.

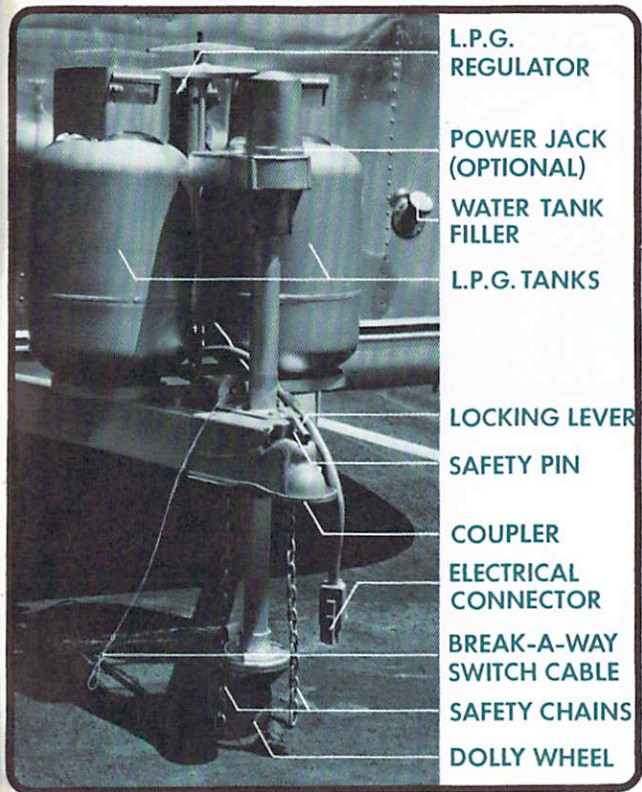

Hitching your Airstream to your car is something that will become almost second nature to you. You will develop your own technique with practice but there are a few tips, learned from experience, which will help you.

- The first thing to do is to jack up the trailer hitch until there is clearance for the hitch ball to slide under. Raise the locking lever on the hitch.
- The car now should be backed, straight back, to the hitch connection. This can be made easier by placing a strip of tape on the rear window of your car and another on the front window of your trailer. By sighting over these two strips of tape you will be able to line up the ball under the hitch by yourself. Of course, the job is much easier if you have the help of another person and use prearranged hand signals.
- If you have a leveling type hitch on your car, jack up the trailer to the full height of the jack before pulling up the leveling bars. A little practice with your hitch will teach you how far to pull up the leveling bars to get the car and trailer level. Always do this on level ground. Proper and improper hitch installations are shown in illustration on page 30. As shown in the hitch installation diagrams, Airstream suggests that the tension on the load equalizing hitch be adjusted so that the hitch and car rear are slightly high. This will give you the best towing characteristics, especially on tandem axle trailers.
- Plug in the electrical connector. Check connectors at both ends, check running, directional and stop lights. Should there be any need to check out wiring on your electrical connector, refer to chapter for wiring diagram.
- Attach breakaway brake cable to car. Attach safety chain to car. Note: In many states it is illegal to attach the

hitching up

TOWING TIPS



safety chain to the hitch in front of the ball and for good reason. If there ever is an accident, the most logical failure would be at the ball. Always attach the safety chain to your car's frame or to the hitch at some other point.

- g. Retract the hitch jack to its full height for maximum ground clearance. Remove the dolly wheel or jack pad and stow it in your car's trunk or some other safe place. **Never tow your trailer with the jack down and the dolly wheel on.** The dolly wheel is not designed to be left on the jack and may fall off and become lost during travel. Move the car ahead slowly and test the trailer brakes. Have someone verify the operation of your trailer's running and stop lights.

STARTING OUT CHECK-LIST.

Before you start out, always make it a practice to go through the following check-list:

1. Disconnect and stow the electrical hook-up cord.
2. Disconnect and stow sewer hook-up hose.
3. Disconnect and stow water hook-up hose.
4. Turn off gas line shut-off valve (under top of range), and oven shut-off valve (International models only).
5. Remove and stow leveling jacks and wheel chocks.
6. Check hitch to make certain it is properly attached by cranking down the hitch jack until the rear bumper of the car is raised about 6 inches above normal.
7. Raise jack to full height, remove and stow dolly wheel.
8. Turn off all interior lights.
9. Lock all interior cabinet doors and place locking pin in refrigerator door. On all folding and foldette doors, be sure to use fastener to hold door open.

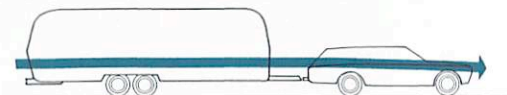

RECOMMENDED
HITCH SLIGHTLY HIGH REAR SLIGHTLY HIGH

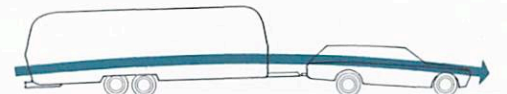

TRAILER HITCH HIGH — CAR REAR HIGH
HOOKUP IMPROPER, TOO MUCH TENSION ON LOAD EQUALIZING BARS

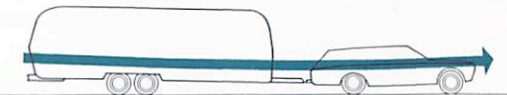

TRAILER HITCH LOW — CAR REAR LOW
HOOKUP IMPROPER, NEED MORE TENSION ON LOAD EQUALIZING BARS

PROPER HITCH INSTALLATION

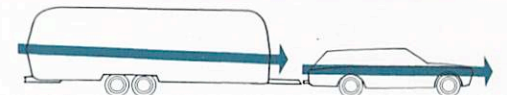

TRAILER HITCH LOW — CAR LEVEL
HITCH BALL TOO LOW

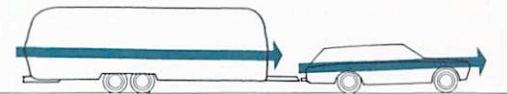

TRAILER LEVEL — CAR REAR LOW
HITCH BALL TOO HIGH

IMPROPER HITCH INSTALLATION

10. Close windows and vents, lock door (see paragraph at end of this chapter, "Securing the Main Door").
11. Pull up the step.
12. Check clearance, tail and stop lights.

Experienced trailer travelers make it a habit to move their rig ahead about 50 feet, stop, get out and walk back and check the ground where the trailer has been standing. This practice can save you countless dollars and annoyances from lost tools and other gear.

Get into the habit of regularly checking the lug nuts on your tires and the tire pressure. Traveling over bumpy, rough roads can loosen lug nuts and if the wheel should come off it could cause severe damage to your Airstream. Experienced trailer travelers always check the condition of their tires, the tightness of the lug nuts and the tire pressure before "hitting the road."

LOADING YOUR AIRSTREAM.

When you took delivery of your Airstream, you received a trailer that was the result of millions of miles of road testing and towing in every climate and terrain. The center of gravity and weight placed on your car's hitch has been precisely calculated to provide the easiest possible towing. You can maintain this easy-towing by following two basic rules.

1. **Keep your trailer as light as possible.**
2. **Distribute the weight as evenly as possible.**

The amount of baggage and personal gear that you take is determined by how you like to travel and where you will be traveling. The vast majority of new trailerists carry considerably more items and food supplies than they really need. After several trips you'll learn to keep the list down to only what you really need in order to conserve weight and space.

However, every item that you take along is one more thing that you will have to stow before going on the road and will add just that much more weight which your car must pull. Regardless of what weight of personal belongings you take with you, always make certain that you maintain the perfect balance that has been built-in your Airstream. **The loaded Airstream should have 12% to 15% of its total weight on the trailer hitch.**

A hitch that is too light can cause the front end to float and the trailer to weave at higher speeds. When it is too heavy it may prove too much for your car.

Your Airstream is designed with storage space arranged in such a way that if ordinary things are put in ordinary places the weight will come out about right. Heavy items such as canned goods, cooking utensils, books, etc. should be placed in lower storage areas near or forward of the wheels. Stowing items in this way will help to maintain your low center of gravity. Light and bulky items such as blankets, clothing and some packaged foods should be placed in upper storage areas.

Keep fragile things well forward of the axle as the front of the trailer is stabilized by the hitch, while the back will tend to bounce more.

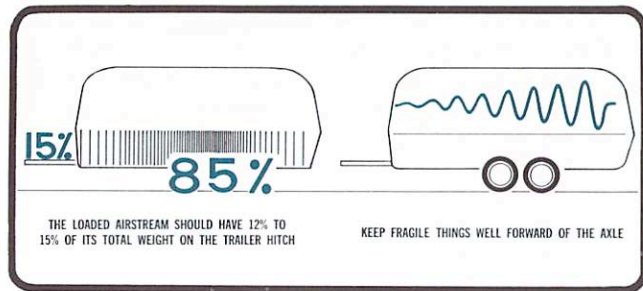

loading

TOWING TIPS



Secure loose items left out in the open to prevent them from sliding around while you are towing. Stack loose material such as chairs on the floor. Lash down smaller objects that are not put into a cabinet.

Items like leveling jacks, blocks and other items related to hitching and unhitching should be stored in the trunk of car, not in baggage trunk of trailer.

Never carry pierced containers of liquid in the refrigerator; always make certain that all containers are tightly sealed. Liquids such as milk and juices should always be transferred to plastic containers with tight fitting caps. If you must carry paper cartons, place a sheet of heavy cardboard between the carton and wire shelf to prevent the wires from wearing through the carton.

The extra care that you take while you are loading your trailer will pay off in reduced strain on your car's engine and springs. This may not be too important on super highways, but a few hundred miles of rutty country road will prove the wisdom of loading your trailer properly. As you become a more experienced trailer traveler, you will undoubtedly pick up tricks such as using aircraft shock cord to lash down radios and other objects you don't want to put in cabinets; placing hooks in strategic places so that the shock cord can be quickly attached. When packing your cupboards remember that a partially empty cupboard will permit the contents to move about and become damaged; it is better to have one full roof locker and one empty one than two which are half filled.

TOWING SKILLS.

There are six specific driving skills the trailer-towing driver must master:

1. Getting Under Way

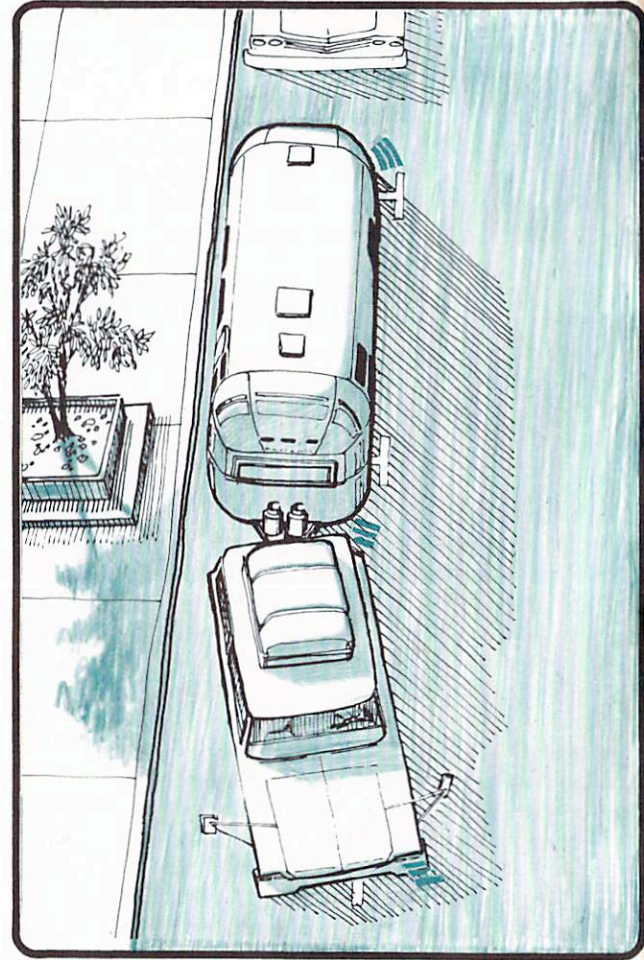

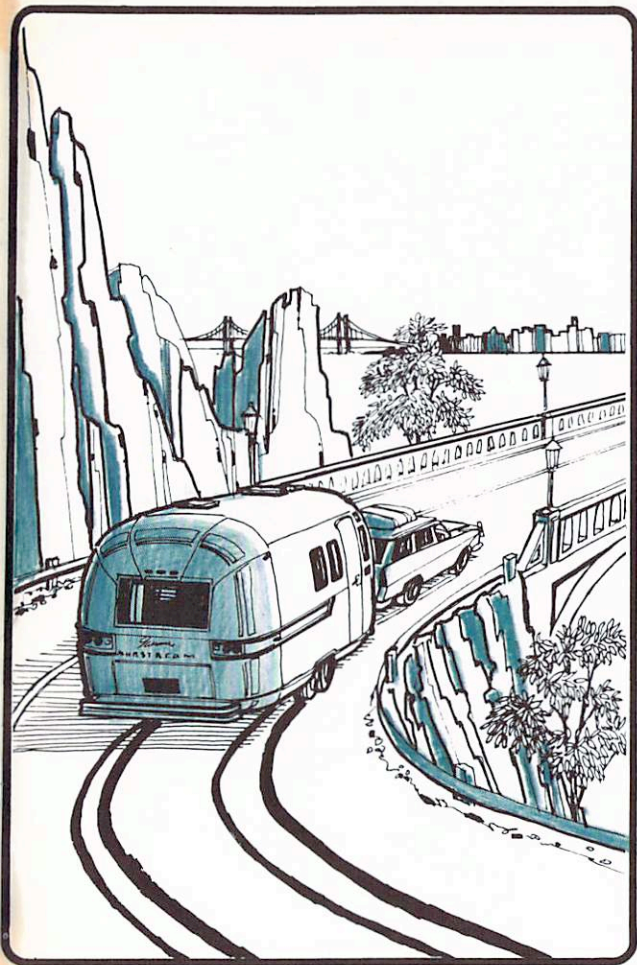

2. Turning Corners and Rounding Road Curves
3. Overtaking and Passing
4. Being Overtaken and Passed
5. Slowing and Stopping
6. Backing

These skills should be practiced out of traffic, and it is a good idea to have someone along with you to watch the right side of the car and trailer while you are learning these skills.

1. Getting Under Way.

Start the car slowly; after having checked the traffic and signaling, you are going to pull into the traffic lane. Accelerate slowly and evenly. Check the mirrors frequently to observe the traffic behind you and the action of the trailer and then move carefully into the proper traffic lane.

2. Turning Corners and Rounding Road Curves.

This is where you will encounter one of the first basic differences with a trailer. The trailer wheels will not follow the path of your car's wheels. The trailer will make a closer turn than the car. This is called trailer "off-track."

In order to compensate for off-track when making turns, pull the car out further than you would normally at the intersection. In case of a right turn, pull the car deep into the intersection so that the trailer clears the curb or any parked vehicles along the curb.

A good way to practice this is by lining out a corner in a large supermarket lot on a Sunday, if it is permissible. The next step is to move to an intersection with very light traffic.

Making a left turn requires the same technique, with a wide swing into the new lane of traffic in order to keep the trailer from edging into the opposing lane.



On sharply curving roads, keep well toward the center of your lane, away from the pavement edge. This procedure allows the trailer to clear the edge of the pavement with enough room so the wheels won't drop off onto the shoulder. Cutting it too close can cause dangerous trailer sway. Care must be taken, also, not to overcrowd or cross the center line, and all turns should be taken at low speed. Take a tip from professional drivers when rounding turns; instead of staying at full speed and then putting on the brakes, slow down well in advance of the turn, enter it at reduced speed, then accelerate smoothly as you come out again onto the straight-away.

3. Overtaking and Passing.

Remember that when you pass another vehicle, you will require longer than usual to accelerate and that you must allow for the length of the trailer when returning to your lane. On freeways and expressways, try to pick the lane in which you want to travel and stay in it.

4. Being overtaken and Passed.

When a large bus or truck overtakes your rig, you will note, despite the best hitch, a reaction from the trailer as the larger vehicle rushes by. The displaced air will tend to push the rear of the trailer quickly to the right and will affect the front of the trailer the same way. Ever so slightly, steer your car to the left into the rush of air. Do not apply brakes, or you may make things worse. Accelerating **slightly** may also help.

Frequently you will note that because of your slower speed cars will be lining up behind you on a two-lane road. It is both courteous and sensible to signal, pull onto the shoulder, and let them pass. It reduces passing hazards, saves

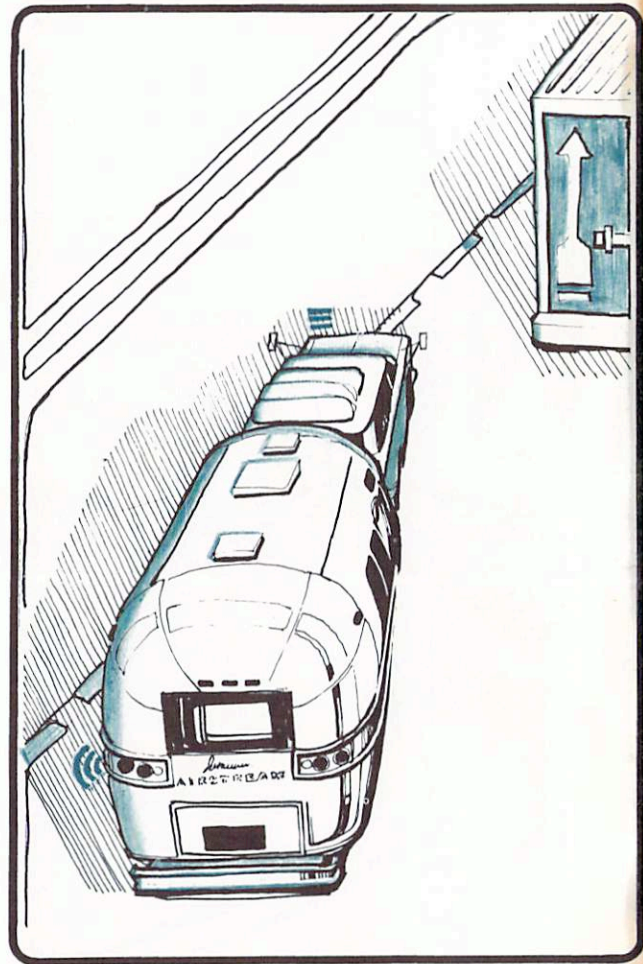

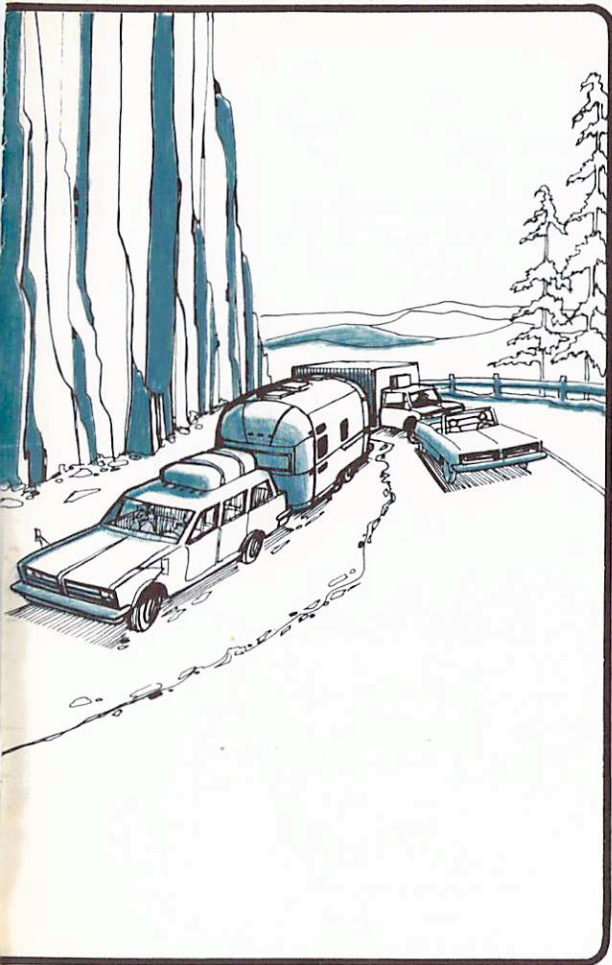

temper, and allows time to check your whole rig.

5. Slowing and Stopping.

When stopping on dry and normal pavement, applying your Airstream brakes simultaneously with your car's brakes will stop your entire rig in approximately the same distance that your car's brakes will stop your car alone. When stopping on a hill or slight grade, if leaving the car in gear is not sufficient to keep the outfit at a standstill safely, chock the wheels with a block of wood. Whenever you park your Airstream on a hill or slight grade and unhitch the car, always block the wheels of your Airstream. Do not use break-away switch as a parking brake since it will burn out the brake magnet and discharge the trailer battery if left on for a sustained period.

When you are stopping on slippery pavement, never use engine drag to help you slow down because the drag on the rear wheels may cause skidding and jackknifing. When stopping on slippery pavement, using your trailer brakes slightly in advance of your car's brakes will prevent any tendency to skid and jackknife. When driving on icy roads take it slowly and if it feels that the car is skidding, gently apply the trailer brakes to keep the trailer and the car in a straight line. Chains do not do any good on trailers.

Make certain that your brake resistor is properly adjusted so that your trailer brakes operate smoothly and in timing with your car brakes. See the directions included with the brake kit for proper adjustment of the resistor.

6. Backing Your Airstream.

Backing your Airstream is really quite simple. The important thing to remember is to do everything slowly and to correct immediately if the trailer starts turning in the wrong direction. See figure on page 36.



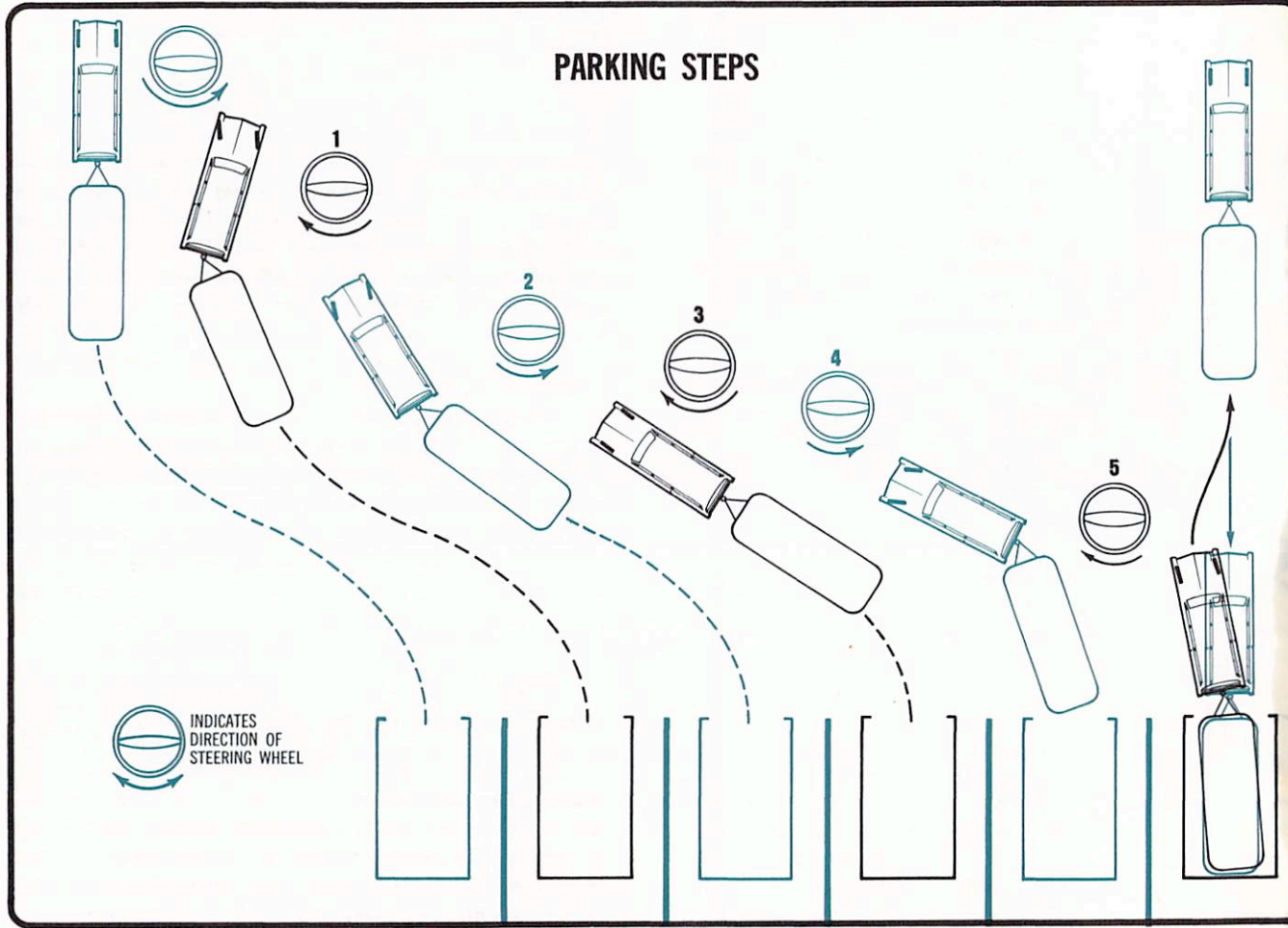

Concentrate on the rear of your trailer. The first thing to do is to aim it in the direction in which you wish to back. Grasp the steering wheel of your car at the bottom and while backing as slowly as possible turn the wheel in the direction you want the rear of your trailer to go. (See step 1). Watch, either in your side rear view mirror or by sticking your head out the window, until the rear of your trailer is pointing in the right direction. Next, while backing slowly, turn the steering wheel slowly in the opposite direction. Your car is now following the trailer in an arc (see step 2). To straighten the car and trailer, turn the steering wheel more sharply. Then, when the car and trailer are in line, straighten the wheel (see step 3).

To start the trailer in a new direction, again turn the bottom of the steering wheel in the direction you want your trailer to go. As soon as the rear of the trailer has turned in the right direction slowly turn the steering wheel in the opposite direction and follow the rear of your trailer around the new arc (see step 4).

To go straight back pull the trailer forward until car and trailer are in a straight line. Put the car in reverse and back slowly making small corrections with the steering wheel as necessary to keep in a straight line (see step 5). If the trailer gets out of line, stop, move forward a few feet and start over again.

A few hours practice in a large parking lot or on a deserted road will make you an expert in backing your Airstream. Keep in mind that a quick turn of the steering wheel will change the direction of the trailer while slow movements should be used for correction. If the trailer should jack-knife, or is not turning fast enough, pull forward a few feet and start again.

GENERAL TOWING TIPS.

You will substantially increase your gas mileage if you can avoid unnecessary starting and stopping. Before you come to stop signals, slow down and time it so that you will not have to stop completely.

The key to towing any trailer is to do it smoothly. Starting and stopping slowly and smoothly saves gas, wear on your car and prevents damage to the items stowed in your trailer. Your Airstream is designed to be towed at any legal speed that is safe for your car alone, and you will find that your Airstream tows and follows your car so effortlessly you may soon forget it is behind you. Never permit yourself to do this. When you are towing the trailer you should always maintain an interval with the car in front of you of at least a car and trailer length for every 10 miles of speed. This gives you ample time to stop in the event of an emergency. Refer to page 40 for state regulations in regards to trailer towing speeds.

When going up a long grade, shift into a lower gear well in advance of when your engine labors. When going down a hill (in dry weather) use a lower gear, or a lower range if you have an automatic transmission, so that the compression of the car engine will slow your whole rig.

One of the hardest things on any trailer is a sharp dip or depression in the highway such as you may encounter on cross streets where gutters continue through the intersection. This straight up-and-down thrust can very easily damage any item left loose in your trailer. Take dips and depressions slowly and easily and be certain that the trailer as well as the car has passed them before resuming normal speed. If the rear end of the trailer drags bottom, it will not do any damage if you are traveling slowly.

general tips

TOWING TIPS



OVERHEATING.

To prevent overheating when driving in the mountains, never let your car labor. Shift to a lower gear, or range if you have an automatic transmission, before it becomes absolutely necessary. Your car's ability to pull without becoming overheated depends on the engine, the cooling system, the transmission, the weight of your trailer when loaded and the type of terrain over which you are traveling. A little practice will teach you your car's limits and it will pay you in time and money to stay within those limits to prevent heat damage to the engine and transmission. Whenever possible, try to anticipate a potential overheating condition and correct it before it gets out of hand. One tip is to turn off your air conditioner if your car is so equipped. Even though you may get uncomfortable, the air conditioner requires considerable power and is a major factor in overheating your car engine.

If your car has a tendency to overheat, see that (if it's not already installed) a direct drive radiator fan is installed in place of the usual clutch type radiator fan.

Another tip when climbing a steep grade is to turn on your heater as high as possible until the crisis is over. This can get rather uncomfortable but in many cases it means the difference between going over the top of the grade and pulling off to the side to cool off. You will be surprised at how much this will keep your engine from overheating. If you ever do overheat, pull off to the side and keep your engine running at a fast idle. Never turn your engine off if the red indicator light is on. Keep it running until the light goes out and stays out for at least five minutes. If you plan to do much mountain driving where overheating is possible it is suggested that you have a temperature gauge installed

in addition to the indicator light. With a gauge installed you can see when the engine starts to get hot; whereas with the indicator light you do not know it until it is already hot.

In addition if your car is equipped with an automatic transmission we recommend that you install a transmission oil radiator such as the Hayden Trans-Cooler. This will enable the transmission to run cooler and prevent possible damage to it.

When traveling through sand or mud, always keep rolling; let your momentum carry the tow car and trailer through. Do not depend too much on the drive wheels. Stay in the rut of the car ahead, if possible, and keep your car in the highest possible gear. The easiest way to get a stuck outfit out of the sand or mud is by towing it out. Carry a length of rope or chain to attach to a passing car or truck for this purpose. If you tow long distances over unimproved roads, the stones and gravel picked up by your tires and thrown back can dent and scratch the beautiful aluminum finish of your Airstream. To prevent this, experienced trailer travelers use masking tape to secure heavy sheets of paper or plastic onto the lower front of their trailers.

SECURING THE MAIN DOOR.

It is very important that the main door of your trailer be completely closed and locked during towing. If it is not properly secured the constant vibration of travel can cause it to fly open and possibly cause damage.

CAUTION: The door latch acts as a deadbolt when it is locked. DO NOT slam the door with the door latch in the locked position. Should you find it difficult to unlock the door, push in to release the pressure on the door latch

As a convenience to you, we have included this Pre-Trip Check List to help ease those worries about your home and making the driving portion of your trip more relaxing.

Home Check List.

- Leave an extra key with your neighbor.
- Store valuables and important papers in a safe place. (Your bank will do this for a small fee).
- Discontinue newspaper, milk and other deliveries.
- Ask the Post Office to hold all your mail for you.
- Arrange with your telephone company for temporary discontinuance or "Vacation Service."
- Arrange for the necessary care of your pets.
- See that your lawn, garden and house plants will be properly cared for.
- Lock all windows and doors securely. Keep shades open for a "lived-in" look.
- Cover all food to keep out mice and insects.
- Eliminate all fire hazards. Place matches in a tin box or glass jar. Store oil, gasoline and other inflammables properly. Destroy newspapers, magazines and oily rags.
- Notify police.

Last Minute Items.

- Pay your automobile insurance to fully cover you and your family throughout the trip.
- Avoid carrying large amounts of cash. Use travelers checks and your Credit Cards.
- Confirm reservations if you have definite overnight stops scheduled.

- Have sunglasses for everyone, especially drivers.
- Pack cameras and film for your post-tour showings.
- Make a check list of clothing and toilet articles for each member of the family.

Motoring Essentials.

- Display car and trailer registration properly. Carry drivers license. In Canada, you will need a non-resident liability insurance card. Obtain special auto insurance before traveling in Mexico.
- Carry an extra set of ignition and trunk keys in a separate pocket . . . or in your wallet.
- Keep an operating flashlight with fresh batteries in the glove compartment.
- Pack the trunk so that you can reach the tools and spare tire without completely unpacking.

Save Room For Yourselves. Avoid packing luggage in the passenger area.

Sharp and Hard Articles. Keep such items where they will not be thrown about in case of a sudden stop. **Wash-and-Wear Traveling Clothes.** Wash out, hang up and they're ready for another day of traveling next morning. **Traveling With Pets.** Carry his dish, water, food, leash and certification papers. **First-Aid Kits.** Include a complete first-aid kit. Car sickness preventatives are a good idea also. **Rest Frequently On Long Trips.** Avoid making your vacation trip a mileage marathon. Make each day's drive relaxing with frequent stops and limited distances.



ALABAMA

MSL: 70 mph days, 60 mph nights on open highway.

OS: Parking off highway is permitted.

DOG: Not allowed.

ALASKA

MSL: 50 mph.

OS: Permitted off highway.

DOG: Permitted in state parks at night.

ARIZONA

MSL: As posted.

OS: Permitted at roadside rest areas unless otherwise posted.

DOG: Permitted if leashed in state and county parks.

ARKANSAS

MSL: 50 mph.

OS: Permitted off highway unless posted.

DOG: Permitted if leashed in state and county parks.

CALIFORNIA

MSL: 55 mph.

OS: Not permitted.

DOG: Not permitted in state park system. Permitted in most county parks, and country-run state parks if leashed.



Trailer traveling through our United States requires a knowledge of many state regulations. Here through the cooperation of Trailer Life Magazine, North Hollywood, California is a brief summary of three of these regulations. (1) **Maximum Speed Limit** of vehicles towing a trailer. (2) **Permissibility of making Overnight Stops** on highways or roadside rest areas. (3) **Permissibility of keeping a DOG** overnight in State or County parks.

NOTE: State laws may change after the printing of this manual. Watch carefully for posted signs.

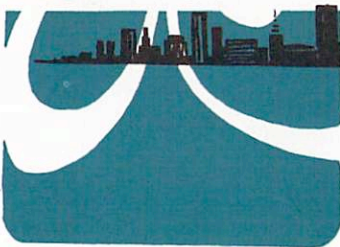
**COLORADO**

MSL: 60 mph open highway, 40 mph open mountain highway.

OS: Permitted off highway.

DOG: Permitted if leashed in state and county parks.

CONNECTICUT

MSL: 60 mph, 70 mph on interstate or limited access highways.

OS: Generally not permitted.

DOG: Permitted if leashed in state and county parks, one pet per campsite. Not permitted on beaches at any time.

DELAWARE

MSL: 50 mph.

OS: Permitted off highway.

DOG: Not allowed.

DISTRICT OF COLUMBIA

MSL: 25 mph or as posted.

OS: Permitted off highway.

FLORIDA

MSL: On turnpikes, 70 mph. On interstate highways, 65 mph days, 60 mph nights. Other highways, 50 mph days, 45 mph nights.

GEORGIA

MSL: 60 mph days, 50 mph nights.

OS: Permitted at roadside park or rest area if not posted otherwise.

DOG: Permitted in state and county

parks .

HAWAII

MSL: Set by local ordinance.

OS: Permitted off highway.

IDAHO

MSL: 60 mph, 55 mph nights.

OS: Permitted in roadside parks or rest areas unless posted otherwise.

DOG: Permitted in state and county parks if leashed.

ILLINOIS:

MSL: 55 mph. Pickups over 8000 lbs. towing trailer, 50 mph.

OS: Not permitted.

DOG: Permitted in state parks if leashed.

INDIANA

MSL: 65 mph. 70 mph on interstate highways.

OS: Not permitted.

DOG: Permitted if licensed and attended.

IOWA

MSL: Trailer under 4500 lbs., 55 mph. Trailer over 4500 lbs., 40 mph.

OS: Permitted off highways.

DOG: Permitted on 6 foot leash.

KANSAS

MSL: On turnpike, 80 mph. In interstate highway, 75 mph days,



60 mph nights.

OS: Permitted off highway.

DOG: Permitted if leashed.

KENTUCKY

MSL: 60 mph days, 50 mph nights.

OS: Permitted off highway.

DOG: Permitted in state and county parks if leashed.

LOUISIANA

MSL: 35 mph.

OS: Permitted off highway.

DOG: Permitted in state parks if leashed.

MAINE

MSL: 45 mph.

OS: Permitted off highway.

DOG: Permitted if leashed.

MARYLAND

MSL: 50 mph.

DOG: Permitted in state forests, but not state parks.

MASSACHUSETTS

MSL: Divided highways, 50 mph.

Other highways, 40 mph.

OS: Determined by local regulations.

DOG: Permitted on 10 foot leash.

Not allowed on beaches.

MICHIGAN

MSL: 50 mph.

state laws

TOWING TIPS



OS: No information available.
DOG: Permitted if leashed.

MINNESOTA

MSL: 65 mph days, 55 nights.
OS: Permitted off highway.
DOG: Permitted on 6 foot leash.

MISSISSIPPI

MSL: 50 mph or as posted.
OS: Permitted off highway.
DOG: No information available.

MISSOURI

MSL: On Federal divided highways, 70 mph. Other highways 65 mph days, 60 mph nights. Cities, towns and villages 55 mph unless otherwise posted.
OS: Permitted off highway.
DOG: Regulations vary, inquire at each park.

MONTANA

MSL: 50 mph.
OS: Permitted as posted.
DOG: Permitted if leashed.

NEBRASKA

MSL: Less than 23 foot trailer, same as autos. 23 foot and over, 50 mph.
OS: Permitted off highway.
DOG: Permitted in state parks if leashed. Check at county parks.



NEVADA

MSL: "Reasonable and proper," or as posted.
OS: Permitted off highway.
DOG: Permitted if leashed.

NEW HAMPSHIRE

MSL: 45 mph.
OS: Permitted off highway.
DOG: Permitted in state parks.

NEW JERSEY

MSL: 50 mph.
OS: Permitted.
DOG: Permitted in state and county parks.

NEW MEXICO

MSL: 60-70 mph days, 50 mph nights.
OS: Permitted off highway.
DOG: Permitted if leashed.

NEW YORK

MSL: 50 mph.
OS: Not permitted.
DOG: Permitted if leashed and proof of rabies inoculation.

NORTH CAROLINA

MSL: 45 mph.
OS: Permitted off highway.
DOG: Permitted in state parks on 6 foot leash.

NORTH DAKOTA

MSL: 60 mph days, 50 mph nights.

OS: Permitted off highway.

DOG: Permitted on leash.

OHIO

MSL: 60 mph days, 50 mph nights.

OS: Not permitted.

DOG: Not permitted.

OKLAHOMA

MSL: Passenger car/trailer

50 mph. Pickup/trailer 65 mph

days, 55 mph nights. 1000 lb.

load, 50 mph.

50 mph.

OS: Permitted unless posted otherwise.

DOG: Permitted if leashed.

OREGON

MSL: 55 mph. If not posted,

"reasonable and prudent."

OS: Permitted at roadside rest areas.

DOG: Permitted if leashed.

PENNSYLVANIA

MSL: 50 mph.

OS: Permitted off highway.

DOG: Permitted if leashed.

RHODE ISLAND

MSL: 35 mph.

OS: Permitted off highway.



DOG: Permitted.

SOUTH CAROLINA

MSL: 55 mph.

OS: Permitted off highway.

DOG: Check at each park.

SOUTH DAKOTA

MSL: 70 mph days, 60 mph nights.

OS: Permitted off highway.

DOG: Check at parks.

TENNESSEE

MSL: Interstate highways, 65 mph.

Other highways 50 mph or as posted.

OS: Permitted at roadside parks or rest areas.

DOG: Permitted in state parks if leashed.

TEXAS

MSL: 60 mph days, 55 mph nights.

OS: Permitted off highways.

DOG: Permitted if leashed.

UTAH

MSL: As posted.

OS: Permitted off highway.

DOG: Permitted if leashed.

VERMONT

MSL: 50 mph or as posted.

OS: Permitted off highway.

DOG: Permitted in state parks on

state laws

TOWING TIPS

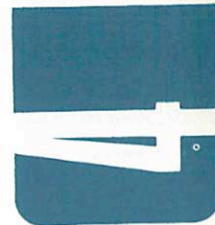

7 foot leash if there is no beach.

VIRGINIA

MSL: Interstate or four lane divided highways, 50 mph. Other highways, 45 mph.

OS: Permitted off highway.

DOG: Permitted if leashed.

WASHINGTON

MSL: Days, 60 mph in 70 mph zone, 50 mph in 60 mph zone.

Nights use posted truck speed.

OS: Permitted off open highways only, not at roadside rest areas.

DOG: Permitted if leashed.

WEST VIRGINIA

MSL: 55 mph.

OS: Permitted off highway.

DOG: Permitted if leashed.

WISCONSIN

MSL: 65 mph days, 55 mph nights.

OS: Not permitted.

DOG: Permitted at state parks if leashed. Check at county parks.

WYOMING

MSL: Four lane divided highway, 70 mph. Other highways, 65 mph.

OS: Not permitted.

DOG: Permitted in state parks if leashed.

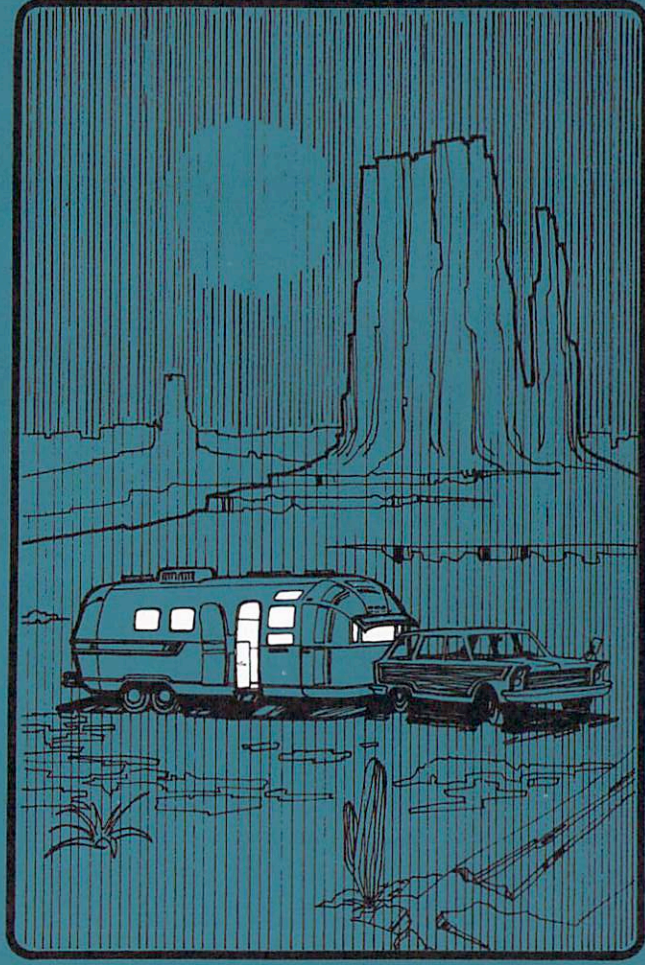

5

OVERNIGHT STOP EXTENDED STAY

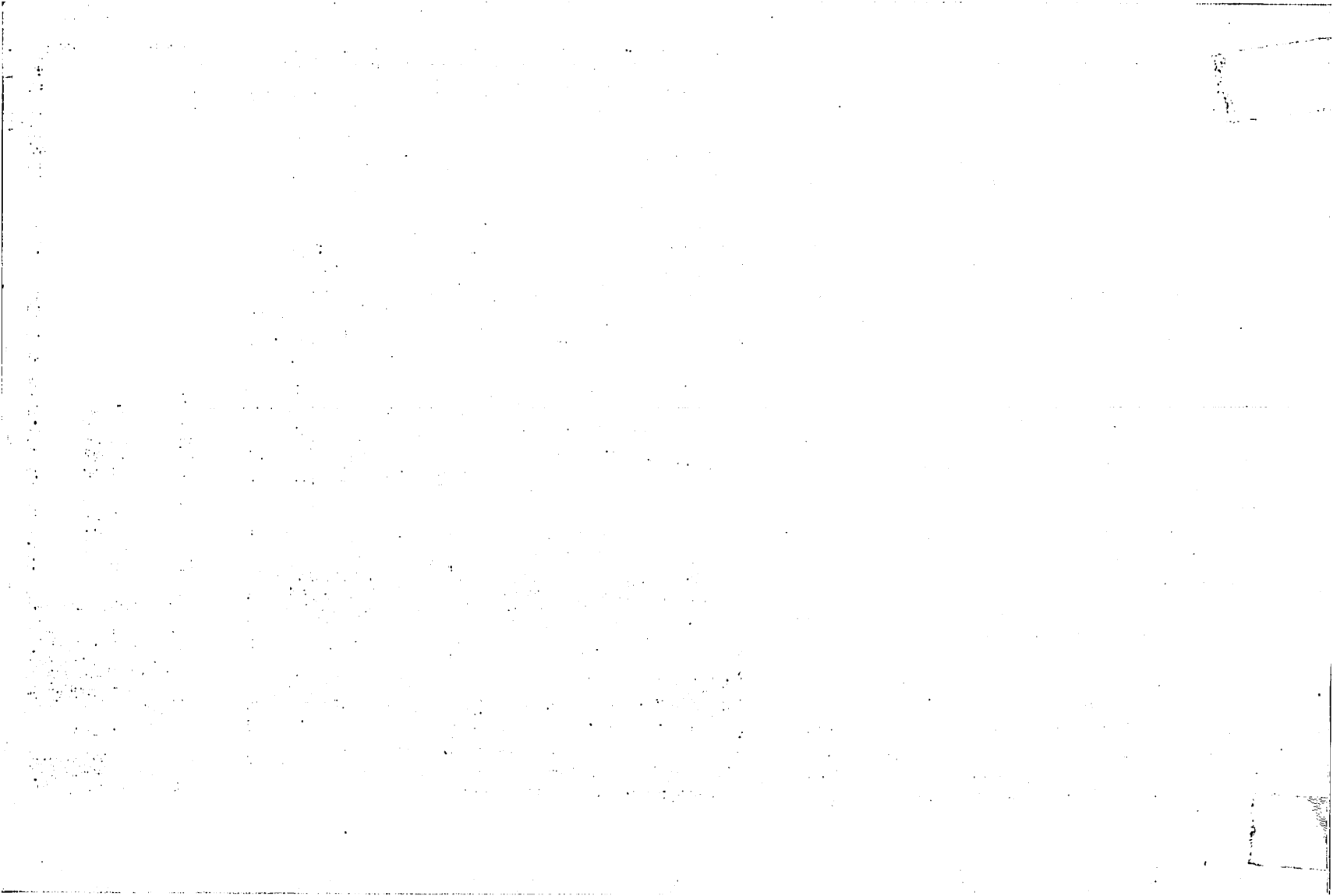

STOPPING FOR THE NIGHT.

When you bought your Airstream you freed yourself from the tyranny of the timetable and the necessity of making reservations wherever you go. There is no end to the number and variety of interesting and convenient places where you can park your Airstream overnight, or for several days. Your Airstream is built to be safely parked on practically any spot that is relatively level and where the ground is firm. You have everything with you, self-contained, that you could ask for. Airstream owners have parked virtually every place imaginable from filling stations to farm lands, in driveways, etc. In time you will develop a knack for spotting wonderful little roadside locations by turning off the main highway and exploring. See page 40 for state laws.

The North American continent is generously dotted with thousands of modern, private trailer parks that have special facilities for trailers. These generally offer considerable privacy and easy utility hook-up facilities for electricity, water and sewage... all at modest rates. You will find many Federal, State and Civic trailer parks that are clean, inexpensive and are located in beautifully wooded areas with convenient access to utilities.

On overnight or weekend trips, chances are you will not use up the capacity of your sewage holding tank, deplete your water supply or run down the battery which supplies your 12 volt current. On a longer trip, when you have stayed where sewer connections and utility hook-ups are not available, it will be necessary for you to stop from time to time to dispose of the waste in your holding tank and replenish your water supply. Many gas stations (chain and individually owned) have installed sanitary dumping

stations for just this purpose. Booklets are available which list these dumping stations.

Many trailer travelers who prefer to make their overnight stops "off the beaten path" make it a practice to stop at trailer parks every few days to replenish their water supply and dump the waste from their holding tank.

In stopping for the night, unless the car is needed for transportation, it is not necessary to unhitch. The trailer should be somewhere near level for comfort, and as level as possible for good gas refrigeration during a longer stay. Try to pick as level a parking spot as possible. Stabilizing jacks or blocks probably won't be required for an overnight stay; putting the jack pad on the hitch jack and running the hitch jack down to take the weight off the car's springs should provide enough stability. If you must park on a slope, park down-hill; it is easier to level and stabilize the Airstream this way. Do not use break-away switch as a parking brake since it will burn out the brake magnet and discharge the trailer battery if left on for a sustained period.

All you need to do to enjoy the self-contained luxury of your Airstream is to:

1. Light the water heater, refrigerator and furnace pilots if required. (See chapter 10).
2. Turn on the gas supply at the range (and oven if separate) and light the stove and oven pilots.

Before moving on, be sure to check your campsite, both for cleanliness and to be sure you haven't left anything behind; turn off the gas supply petcock to the range and oven, make sure everything is properly stowed, use your Hitching Up check list (chapter 4), and you are ready for travel adventure.

stopping for the night

OVERNIGHT STOP
EXTENDED STAY



extended stay

OVERNIGHT STOP
EXTENDED STAY

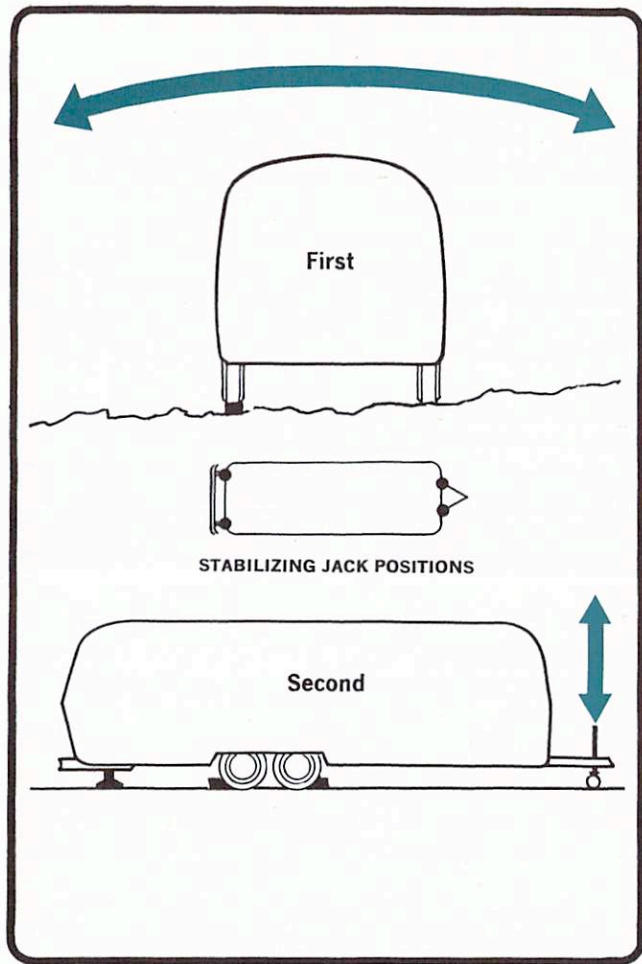

NOTE: Several directories of trailer parks are available, check your dealer for his recommendations.

PREPARING FOR AN EXTENDED STAY.

Making a long trip in your Airstream is not very different from making a week-end excursion. Since everything you need is right at hand you are at home wherever you go. When packing for an extended trip take everything you need, but only what you need. Follow the tips in chapter 3 on stowing your belongings.

When you plan to stay in the same place for several days, weeks or months, you will want your trailer to be as level and steady as possible.

LEVELING.

For comfort and for good refrigeration, it is very important to have your trailer as level as possible. To aid in getting it level, use small spirit levels located as follows:

Two on the hitch — mounted at right angles to each other. Or... two placed at right angles to each other, on the trailer floor.

First, level side-to-side by running the wheels on the low side up a small ramp consisting of a wedge about 3 feet long, tapered from 1" on one end to 4" or 5" on the other end — we do not recommend a hole in which to place a tire for leveling.

Second, get the front and rear at the same level by disconnecting the hitch, putting the jack pad under the jack and adjusting the screw up or down until you are level. Block the wheels to keep the trailer from rolling. Use stabilizing jacks at all four corners to eliminate the natural spring action of the axles and give you a stable floor.

Note: When using stabilizing jacks never put a great deal

of pressure on them when they are placed on the rear bumper of the trailer. Whenever the trailer must be lifted with a jack, as when changing a tire or leveling on very rough terrain, always place the jack under the main frame rail. A 3" aluminum pad is provided to indicate the proper position for the jack. Lifting the trailer by the bumper may cause "canning" of the roof or back end sheets.

Hook up to the water by attaching a 5/8" water hose to the city water service.

Plug the electrical cable, which is stored under the lid of the compartment between the bumper and the rear of trailer body, into the city power service. Be sure you have the wire grounded and have the proper polarity. (See chapter 7.) Hook your waste drain hose into the sewer disposal facility and attach to the drain outlet in your trailer by removing the drain cap, pushing hose on and twisting until it feels secure. Open holding tank dump valve; drain and flush tank; close valve.

Turn on the gas petcock under the top of the stove; light the range and oven pilots. Light the water heater, refrigerator and furnace pilots.

See the appropriate chapters for details on operation of the appliances and systems.

extended stay

**OVERNIGHT STOP
EXTENDED STAY**

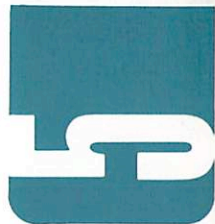

There are four complete utility systems built into your Airstream: Gas, Electricity, Water and Sewage. The next four chapters of this manual are devoted to instructions for operation and maintenance of the utility systems in your Airstream. If you require specialized service, contact your Airstream dealer, the nearest Airstream factory or one of the factory service depots listed under the warranty on the individual appliance.

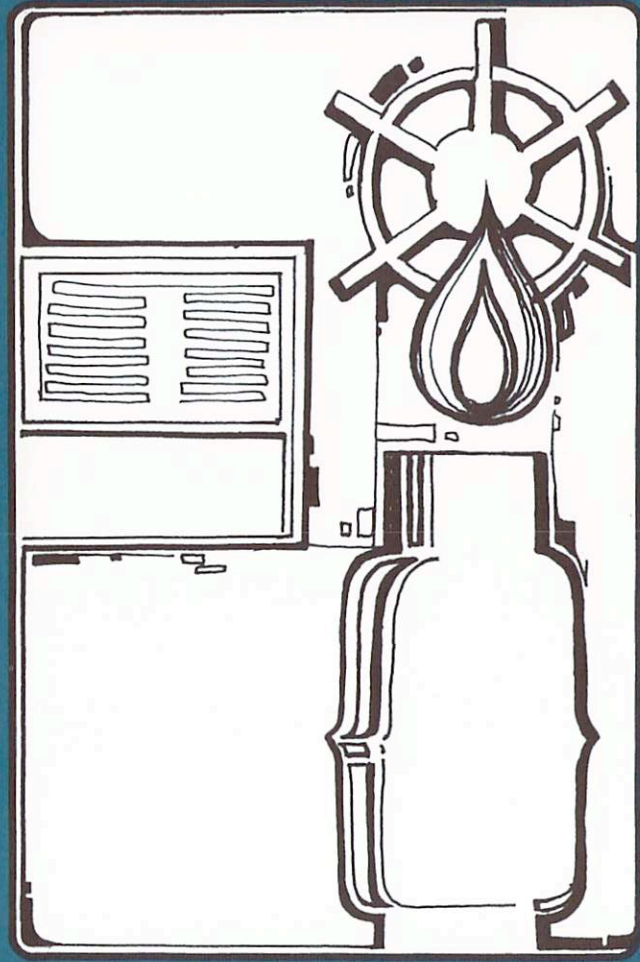

6

L.P.G. SYSTEM

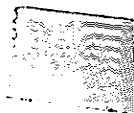

The LPG system schematic in your Airstream is illustrated on one of the following pages. We suggest you cross out the schematics which do not apply to your Airstream to insure future reference to the proper schematic.

Your Airstream is equipped with two tanks for LPG (Liquid Petroleum Gas). LPG burns with a clean blue flame and produces more heat than natural gas. There are two basic types of LPG in common usage: Butane and Propane. Butane is widely used where temperatures are normally above freezing the year around and Propane is used where subfreezing temperatures are common, since Butane freezes at 32°F as compared to -40°F for Propane. All of the orifices in your Airstream LPG appliances are of the universal type which will burn either fuel.

How long a full tank of gas will last is of course dependent on usage. In cold weather when you are using the furnace extensively, large amounts of hot water, and are doing extensive cooking, you will naturally use more than you will in warm weather when you do limited cooking. On the average, with normal cooking and other appliance use, you can probably count on three weeks service from each 28-lb. tank or two weeks from each 20-lb. tank.

International models are equipped with an Automatic Gas Regulator. Both tanks are connected to this regulator and are turned on. Gas is drawn from only one tank at a time and when the tank being used is depleted the regulator automatically switches to the full tank. An indicator on the regulator points toward the tank being used to give you a visual reminder when one tank is empty. The empty tank can be removed for refilling without disturbing the tank being used. Simply close the tank valve, disconnect it, have it filled and reconnect. When the tank

being used is emptied, the automatic gas regulator will automatically switch over, provided the other tank valve is also open.

To remove the gas tanks, disconnect the tubing nut with a wrench and loosen the large knob which holds the tanks in place. The tubing nut has a left hand thread so be sure to always turn it clockwise to loosen and counter-clockwise to tighten. When replacing tanks, connect and tighten tanks before clamping them in place. If you have allowed both tanks to run out, air may have gotten into the lines. In this event the air must be forced out through the lines by the gas pressure before you will be able to light your pilots. Hold a match to the pilot of the appliance closest to the tanks until it lights. Then move to the next closest, etc. For operation of the appliances, refer to chapter 10.

NOTE: In some states it is illegal to leave gas tanks turned on while towing a trailer.

For B.T.U. ratings on all gas appliances refer to chart found in chapter 15.

L.P.G. system

L.P.G. SYSTEM





L.P.G. SYSTEM

l.p.g. system diagrams

23 T
23 D
25 T

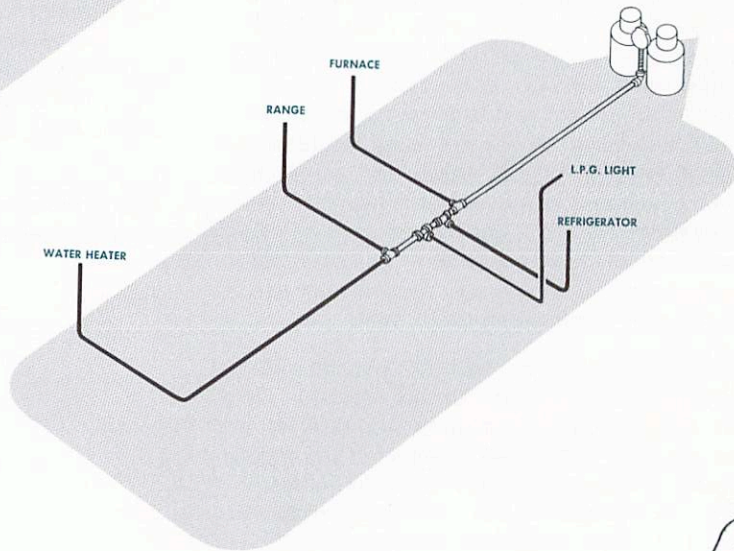
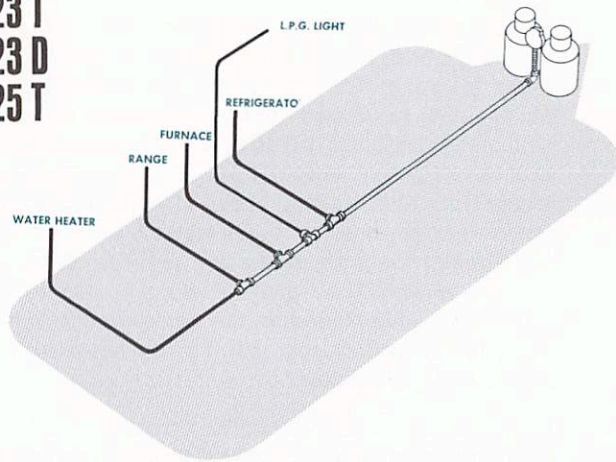

25 D

27 T (L.Y.)

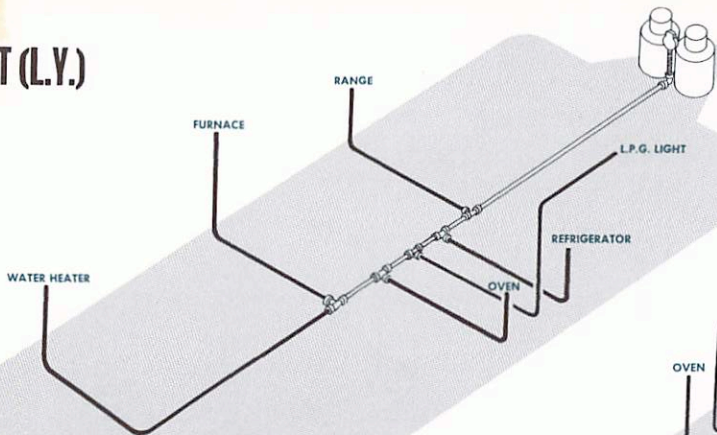

WATER HEATER

27 D (L.Y.)

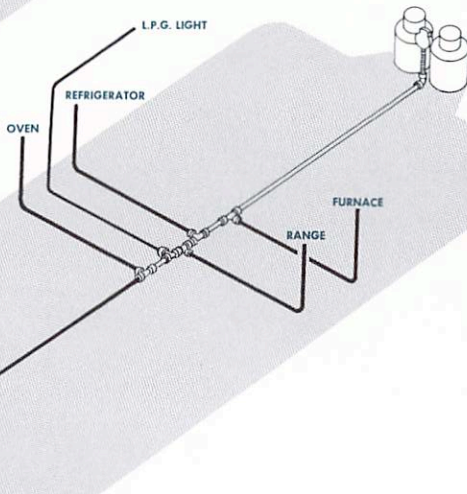

L.P.G. system diagrams

L.P.G. SYSTEM





L.P.G. SYSTEM

L.P.G. system diagrams

27 T (INTL.)

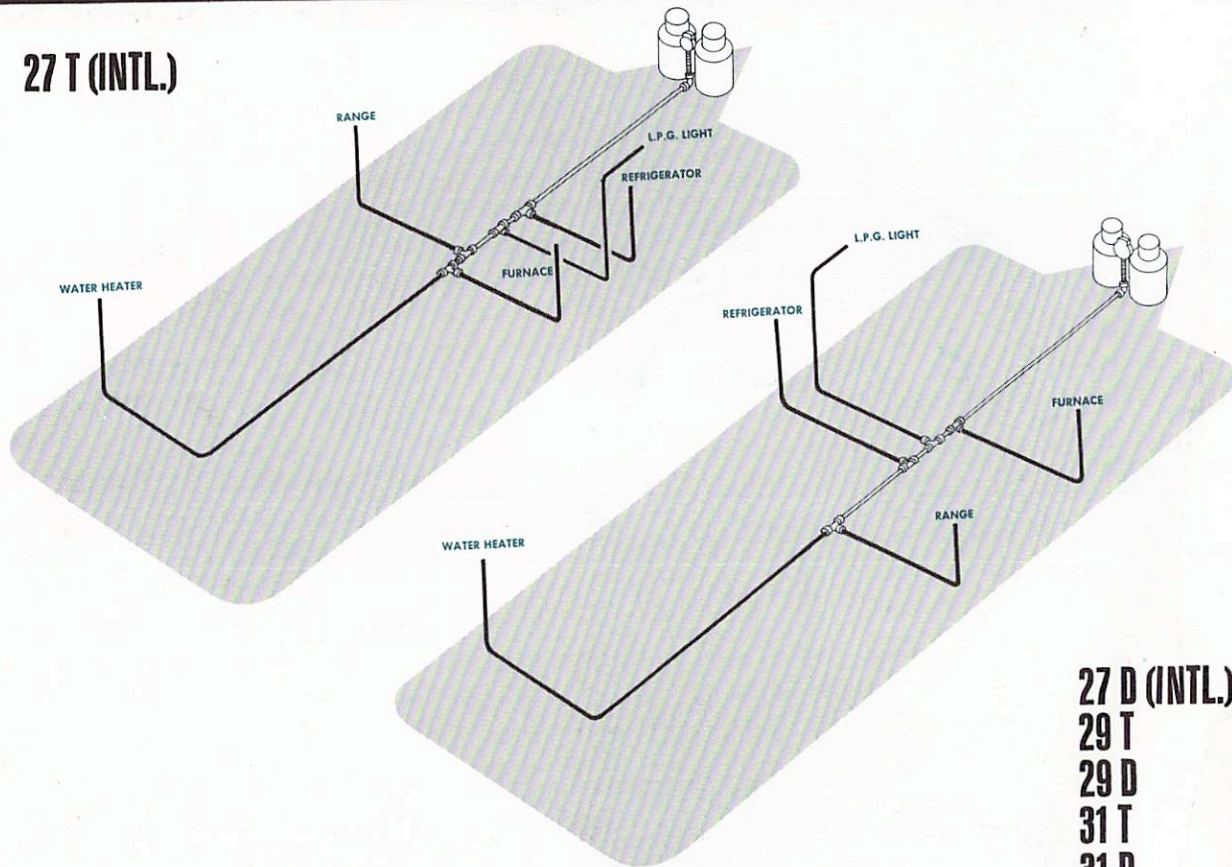

27 D (INTL.)
29 T
29 D
31 T
31 D

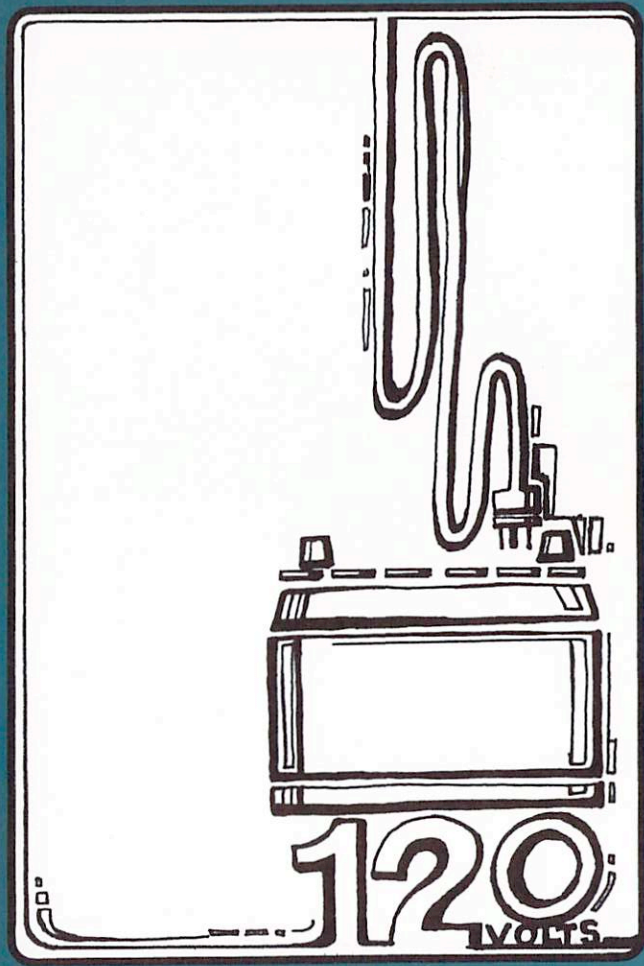

ELECTRICAL SYSTEM

7

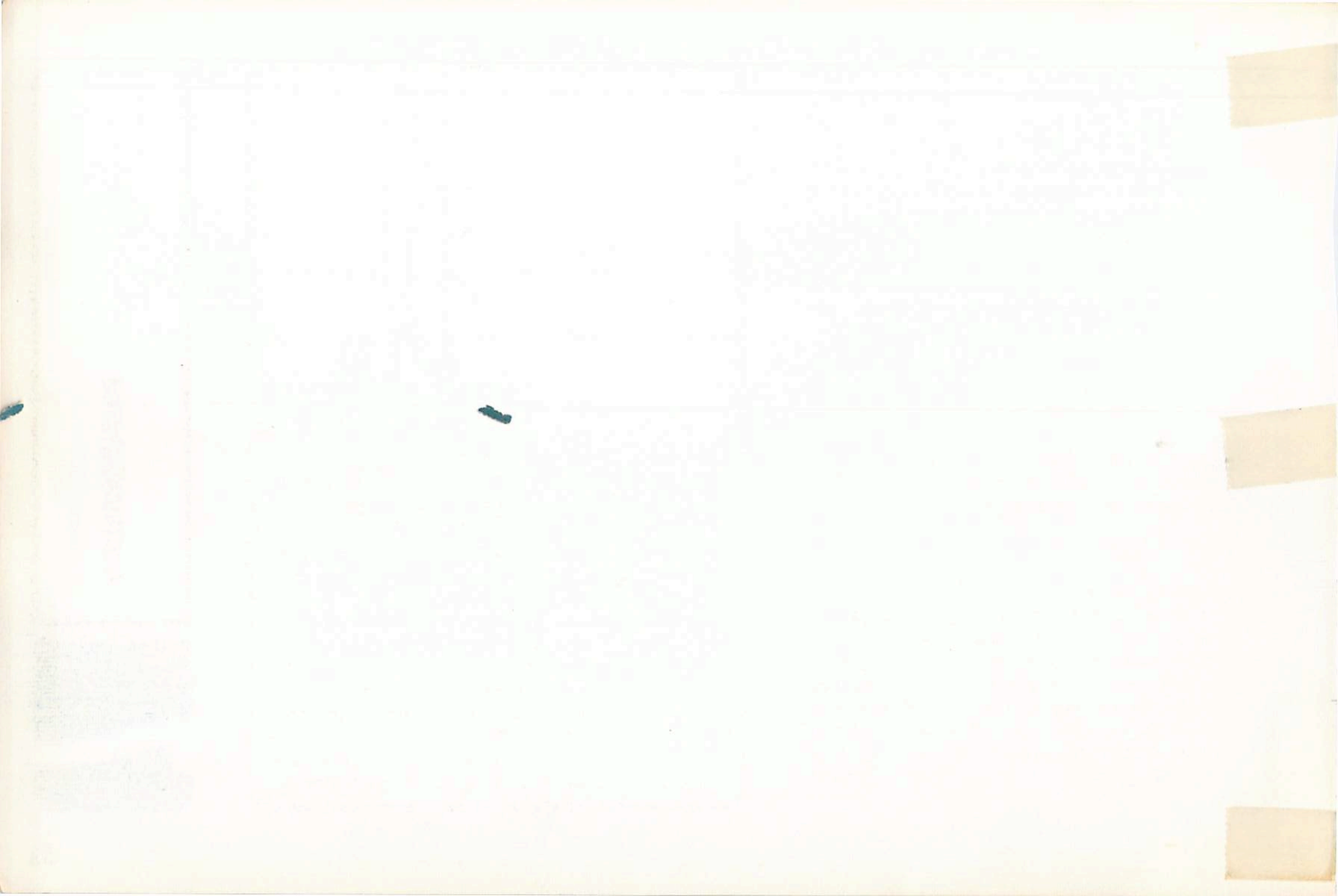

ELECTRICAL SYSTEM.

Your Airstream is equipped with the latest development in trailer electrical systems... the exclusive AIRSTREAM UNIVOLT System. This system enables you to use all your lights and appliances, including the fans and water pump, whether you are operating self-contained on battery power or you are hooked up to 120-volt city power. The UNIVOLT system converts 120-volt power to 12-volt power through a special high capacity combination 12-volt DC power supply and battery charger. This combination unit contains all solid state circuitry and is protected from damage by internal automatic resetting circuit breakers.

The 12-volt light bulbs give the same light as you would expect from regular household bulbs. Additional 120-volt AC convenience outlets are provided for operation of appliances such as T.V., toaster, etc., when trailer is hooked up to 120-volt city power. Another feature of the UNIVOLT system is the CENTRAL CONTROL panel which is discussed later in this chapter.

LIGHTS.

The ceiling light fixtures are operated by 4-position switches located in the fixtures. Starting from the off position and turning clockwise, the switch turns on first one bulb, then three bulbs, then four bulbs, then off. Naturally, when operating on the battery, you wish to conserve power so you will want to use only one bulb in the ceiling fixtures whenever possible. The cone lights in the bedroom have individual 4-position switches for each light fixture, which allows you to select any one of three different light levels.

TO OPERATE SELF-CONTAINED.

The UNIVOLT system is automatically on self-contained battery power whenever the trailer is disconnected from the city power. In case you are connected to city power and wish to operate on self-contained battery power, all you need to do is disconnect the power supply cable from the city power receptacle. Whenever this cable is not being used, store it in the space provided on the hose storage compartment lid.

When the UNIVOLT system is on self-contained battery power, the only items which are inoperable are the 120-volt convenience outlets, the electric operation of the refrigerator, and the air conditioner (if you have this optional accessory).

When your towing vehicle is hooked up to your Airstream, the UNIVOLT system will automatically draw power from your vehicle battery as well as your trailer battery.

TO OPERATE WITH CITY POWER.

To operate the UNIVOLT system in your Airstream from 120-volt AC city power, plug the power supply cable into the city power receptacle. **MAKE CERTAIN THAT THE TRAILER PARK SERVICE IS 120 VOLTS, NOT 220 VOLTS.**

NOTE: You don't need to uncoil the total power supply cord. Just open the storage compartment lid, uncoil the needed amount of power cord, pull this cord out through the access door on the bottom of the storage compartment and plug into city power. It is necessary to ground the service coming into your Airstream to prevent a possible shock to anyone touching your trailer, and as long as you are hooked into electrical service that accepts the three-prong grounded plug, you should not have a problem with polarity or grounding. In older parks and many other locations you will not be able to tie into three wire grounded

lights
self-contained
city power

ELECTRICAL SYSTEM

service. In this event, follow the procedure outlined later in this section.

BATTERY CHARGING WHILE TOWING.

As you drive, the battery in your Airstream and towing vehicle are under constant charge by your towing vehicle's generator or alternator. The batteries cannot be overcharged as the charge rate is controlled by your vehicle voltage regulator.

BATTERY CHARGING WHEN HOOKED UP TO 120 VOLTS.

When your Airstream is hooked up to 120-volt city power, the UNIVOLT system automatically charges the trailer battery (and towing vehicle battery, if hooked up), but the speed of this charge depends on how much power is being used for lights and appliances. Normally the system will provide substantial current for lights and appliances while maintaining your battery at full charge condition.

The system incorporates a unique voltage-sensing section in the charger circuit that automatically controls the charging current. When the battery is fully charged, shut-off is complete; it is impossible to overcharge.

BATTERY CHARGING AT SERVICE STATIONS.

If your battery needs charging and 120-volt power is accessible, we recommend using the automatic built-in charger in your UNIVOLT system, but if this is not possible and you must have the battery charged at a service station, make certain they give the battery a **slow** charge, since a quick charge can drastically shorten the life of the battery. Another practice that can shorten battery life is allowing it to completely discharge too many times.

BATTERY WARRANTY.

The battery in your Airstream is warranted for 24 months.

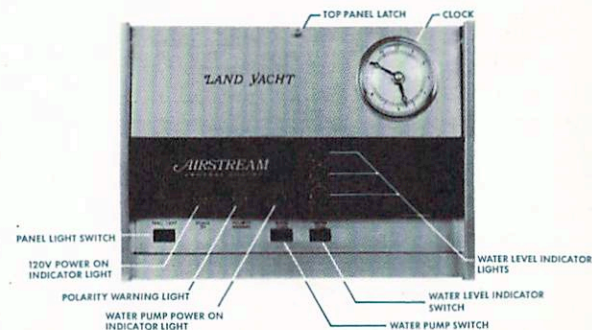
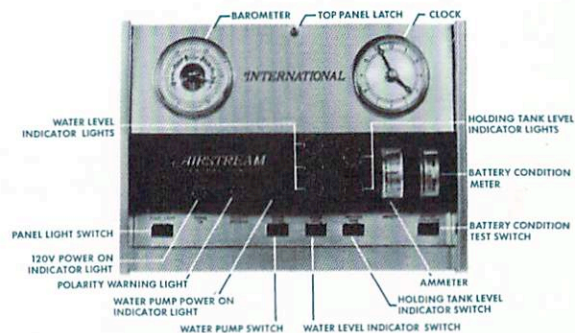

For service or replacement, go to any service station or dealer who sells and services this brand.

CENTRAL CONTROL PANEL.

A feature of the Airstream UNIVOLT system is the CENTRAL CONTROL panel located in the front roof locker. On the front face and behind this panel are various controls, connections and readout devices which will simplify the use of the various systems in the trailer. Specific information on servicing and trouble shooting can be found in control panel service manual. Following are the various items located on the CENTRAL CONTROL panel.

PANEL LIGHT SWITCH. This switch operates a light which illuminates the switch panel.

CLOCK.

This clock is operated by a "C" cell battery which should last from 9 to 12 months. To replace battery or reset time unlatch and open top panel.

BATTERY CONDITION TESTER (standard on International models).

By pressing the button switch under the words BATTERY CONDITION, the needle will indicate whether your battery is in good, fair or bad condition. When the needle shows good condition, the battery is at 12 to 13 volts, fair condition is 11 to 12 volts, and bad condition is 10 to 11 volts. When the battery condition is bad, you should take every reasonable step to conserve power by using as few lights as possible and not operating any unnecessary appliances, so as to be sure to have battery power remaining for such necessary functions as lights and the water pump. This tester will give an accurate reading only when trailer is unhooked from 120-volt city power, because when trailer is hooked up, the battery is being charged by the UNI-

VOLT system and this gives a false reading.

AMMETER (standard on International models).

Normally you will use the ammeter in conjunction with the battery condition tester so as to indicate whether the charge on the trailer battery is being increased or decreased. When the battery condition is bad you will want to limit the battery drain shown by the ammeter to the lowest convenient level. If you wish to operate the car engine to supply additional power from the auto generator to the trailer battery when the battery condition is bad, you can tell from the ammeter whether or not the car is supplying sufficient current to prevent the trailer battery from being drained further.

WATER PUMP SWITCH.

The water pump switch in your Airstream is located on the CENTRAL CONTROL panel. The indicator light above the switch will be lighted when the water pump switch is on.

WATER LEVEL INDICATOR.

A matter of importance to you when you are operating self-contained is the amount of water left in your water tank. This can be determined by pressing the button under the words WATER LEVEL on the CENTRAL CONTROL panel. When this button is pressed, if the tank is at least half full, the "1/2" light will be on; if the tank is at least one-quarter full, but not one-half full, the "1/4" will be on; and if the tank is less than one-quarter full, the % light only will show. If the % light does not light, the tank is almost empty. In rare cases, when tank has been filled with highly pure water (such as from a mountain stream), the indicator lights may not work.

central control

ELECTRICAL SYSTEM

HOLDING TANK LEVEL (standard on International models).

To determine the level of the holding tank, press the button under the words HOLDING TANK. The "½" light will be on, if the holding tank is at least one-half full. The full light will be on if the holding tank is over three-quarters full.

POLARITY WARNING LIGHT.

There is a polarity light located on the CENTRAL CONTROL panel. Whenever you hook up your trailer to 120 volts, using an adapter which allows you to reverse the plug in the receptacle, be certain that the polarity light is off. If not, reverse the plug which should cause the light to go off. Occasionally, when you are hooked up directly through the 3-prong grounding plug without any adapter, the polarity light will glow. As long as you are using the 3-wire system, the trailer is adequately grounded, and there is no cause for alarm.

POWER ON.

Whenever you are hooked up to 120-volt city power the POWER ON light will glow. This light, and the previously discussed polarity light, are two excellent checks on a proper 120-volt connection.

LOCATION OF BASIC ELECTRICAL COMPONENTS.

The UNIVOLT is located at the rear curbside of the trailer, just outboard of the tub. It is accessible through the rear curbside access door. The 120 volt panel is located in the curbside of the front roof locker. The low-voltage panel is part of the CENTRAL CONTROL panel located in the center of the front roof locker. The battery is located in the trunk compartment at the rear of the trailer. It is mounted on a

slideout rack for easy servicing.

When you are operating your trailer on 120-volt city current, the wiring is protected by circuit breakers in the 120-volt panel box. In the event of failure of a 120-volt circuit, check the circuit breaker first. If the breaker continues to trip after you have reset it several times, your circuit may be overloaded with appliances, or there may be a short in the circuit. If lessening the load on the circuit does not solve the problem, consult an electrician. In models with factory-installed air conditioning, a separate 120-volt circuit with a separate circuit breaker is provided to avoid possible overloading of the appliance circuits.

A feature of your AIRSTREAM trailer is the MULTI-DOME system. This is a system of removable panels in the ceiling of the trailer. If there is ever the need, these panels can be removed and would expose almost all of the 12 and 120 volt wiring in your trailer.

WHEN THREE-WIRE GROUNDED SERVICE IS NOT AVAILABLE.

- a. Attach the three-prong plug on your trailer power supply cable to a two-prong adapter. The third conductor line from the adapter has a ground lug. This is your ground line.
- b. Clamp ground line to junction box or other ground such as a water pipe, then insert two-prong plug into the receptacle.
- c. After cord has been connected, check the polarity indicator light. If the polarity warning light is on, pull out the plug, turn it over, and reinsert. The light will now be out, the polarity will be correct and your Airstream electrical system will be grounded.

An excellent additional ground is obtained through the front jack if an aluminum or steel jack pad is used. Do not block the jack pad with wood because this will eliminate this grounding feature.

TROUBLE SHOOTING.

Trouble with the electrical system in your trailer is extremely unlikely. Your Airstream's UNIVOLT system and CENTRAL CONTROL are provided with a series of fuses and circuit breakers for your safety. Should electrical difficulties arise, you will normally be able to locate the source of the problem and correct it with the aid of the following checklist and circuit diagrams. More extensive trouble shooting instructions for the CENTRAL CONTROL are found in the CENTRAL CONTROL service manual.

For details on electric motor amperage, light bulb size, and fuse and circuit breaker location, refer to charts found in chapter 15.

The electrical diagram for your particular model Airstream is illustrated on one of the following pages. We suggest that you cross out the diagrams which do not apply to your Airstream to insure future reference to the proper diagram.

grounding
trouble shooting

ELECTRICAL SYSTEM



SYMPTOM	POSSIBLE CAUSE	REMEDY
No 12-volt power (Lights, appliances do not work)	<ol style="list-style-type: none"> 1. Input line and/or battery not connected 2. Central control fuse blown 	<ol style="list-style-type: none"> 1. Make necessary connections. 2. See items 3, 4, 5, and 6.
Blown fuse	<ol style="list-style-type: none"> 3. Overloaded circuit (over 40 amps) 4. Electrical short 5. Shorted battery 6. Battery terminals not properly connected to UNIVOLT + and - terminals 	<ol style="list-style-type: none"> 3. Turn off switches to reduce load. Open cover of CENTRAL CONTROL and replace blown fuse. 4. Open cover of CENTRAL CONTROL, disconnect power lead from circuit breaker and touch to individual circuit terminals while watching ammeter. Ammeter will show discharge in the shorted circuit. From wiring diagrams check the circuit for defective wiring, lamps or motors. 5. Replace battery and fuse. 6. Make proper connections; replace fuse.
Univolt automatic circuit breaker clicks on and off	<ol style="list-style-type: none"> 7. Incorrect input line voltage (such as 230 volts or improper cycle power) 8. Shorted battery 	<ol style="list-style-type: none"> 7. Connect to 120-volt, 60-cycle power. 8. Replace battery.
Dim lights or sluggish fan motor	<ol style="list-style-type: none"> 9. 25- or 50-cycle power (some foreign countries) 10. Discharged battery (when operating without 120-volt line) 	<ol style="list-style-type: none"> 9. Use 60-cycle power. 10. Charge battery.
UNIVOLT will not charge battery	<ol style="list-style-type: none"> 11. Input line not connected 12. Battery not connected 13. Bad battery 14. Too many lights and appliances in use 	<ol style="list-style-type: none"> 11. Connect input line. 12. Connect battery to UNIVOLT. 13. Replace battery. 14. Reduce electrical load.
Specific gravity of battery is too high (over 1.275)	<ol style="list-style-type: none"> 15. Battery is low on water 	<ol style="list-style-type: none"> 15. Add distilled water to battery.

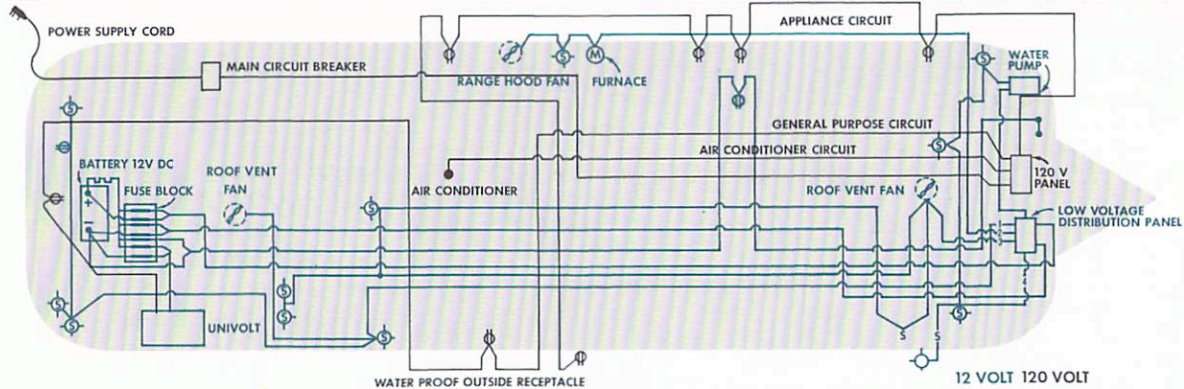

23 T 23 D 25 T (L.Y.)

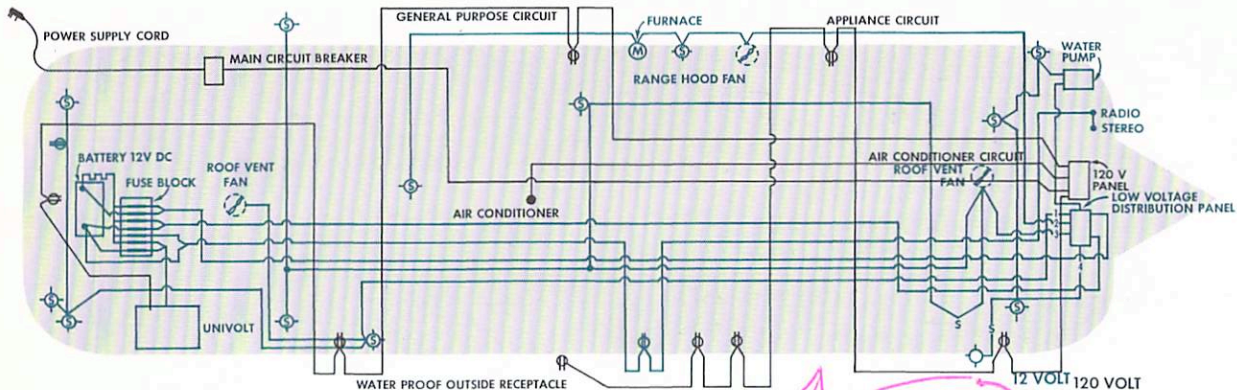

25 D (L.Y.) 27 T (INTL.)

electrical diagrams

ELECTRICAL SYSTEM

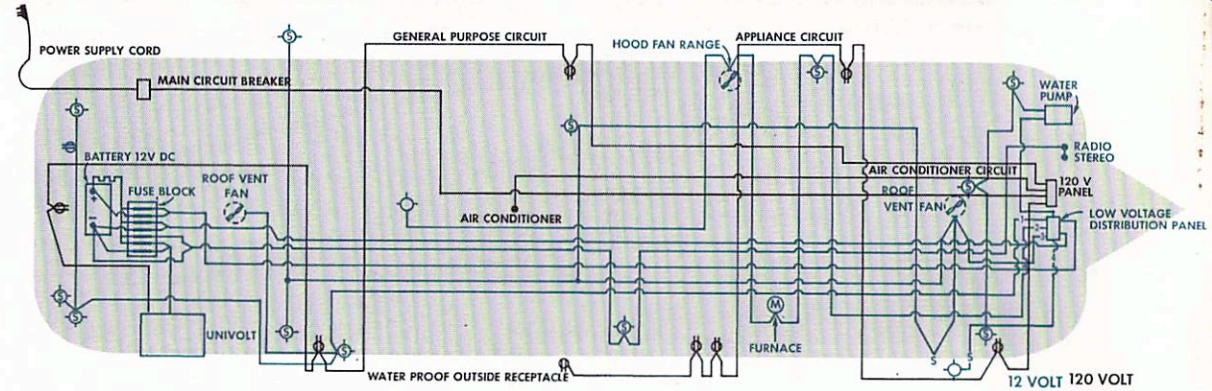

27 T (L.Y.)

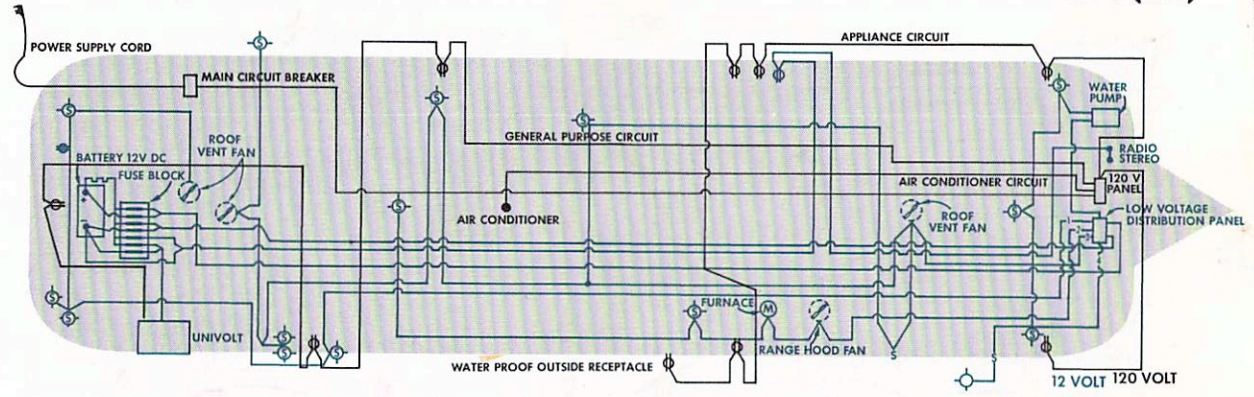

27 D (L.Y.) 27 D (INTL.) 29 T 29 D 31 T 31 D (INTL.)

CENTRAL CONTROL PANEL SCHEMATIC

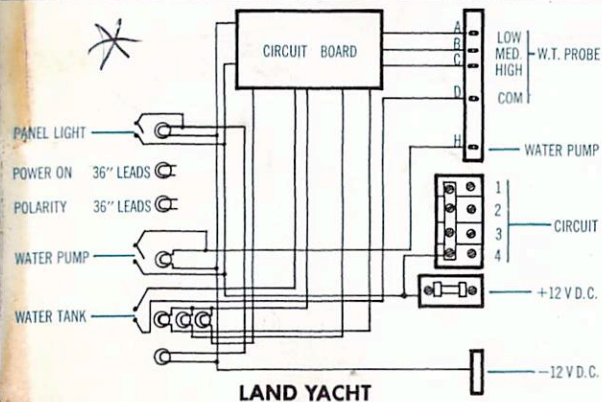
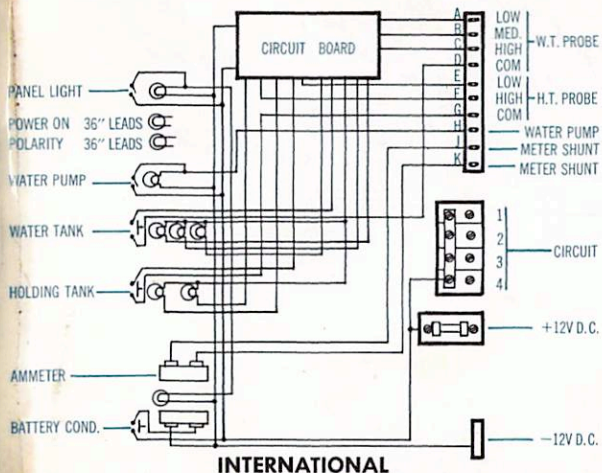

TRAILER-CAR ELECTRICAL CONNECTOR

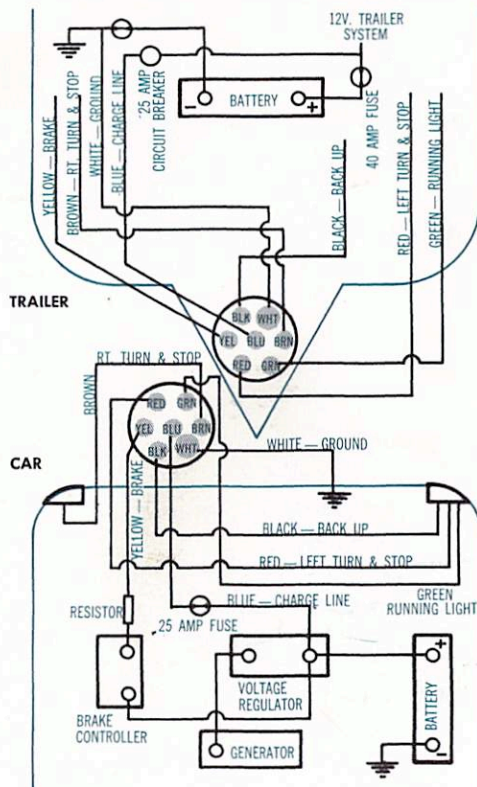

NOTE: Polarity of trailer battery must match polarity of car battery. e.g. If negative pole of car battery is grounded, negative pole of trailer battery must be grounded.

Spare 40 amp fuses should be carried (available at larger auto supply or truck parts stores).

electrical car connection
 central control panel
 schematic

ELECTRICAL SYSTEM

Spindle plug in car line battery. Do not put fuse in car to charge trailer battery. This fuse is

CAR WIRES

PURPLE - BACK UP LIGHTS

These color match
the trailer wires

Car ^{to be} stop switch in trunk rear

Green - Reg. lights

Red - L. turn

Blue - charge line
to trailer Battery

Brown - R. turn

White - ground

Black - Back up

disconnected

Yellow - Car Brake battery in trailer or is
for trailer light from car battery when there is no

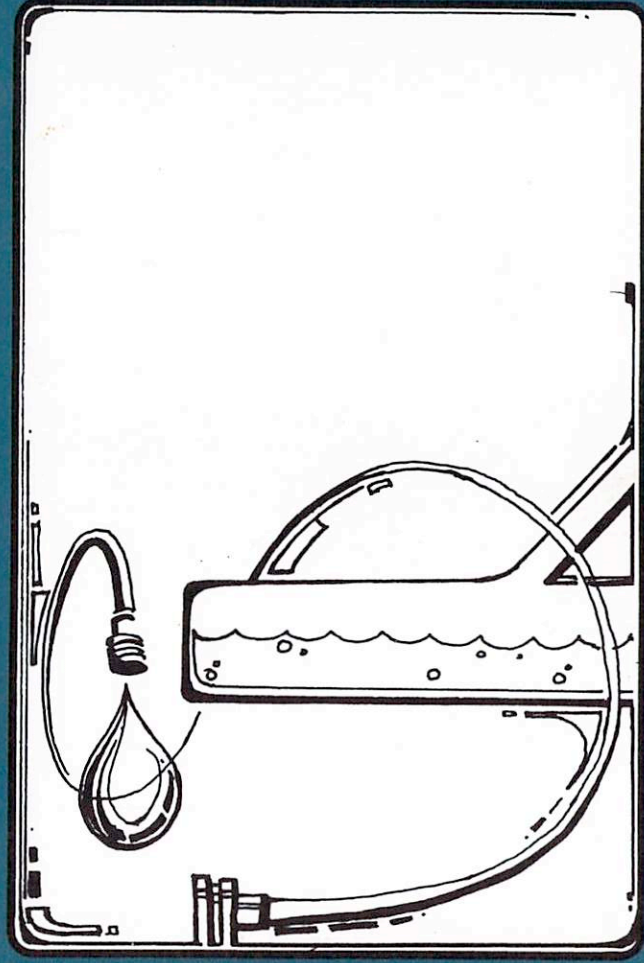

8

WATER SYSTEM

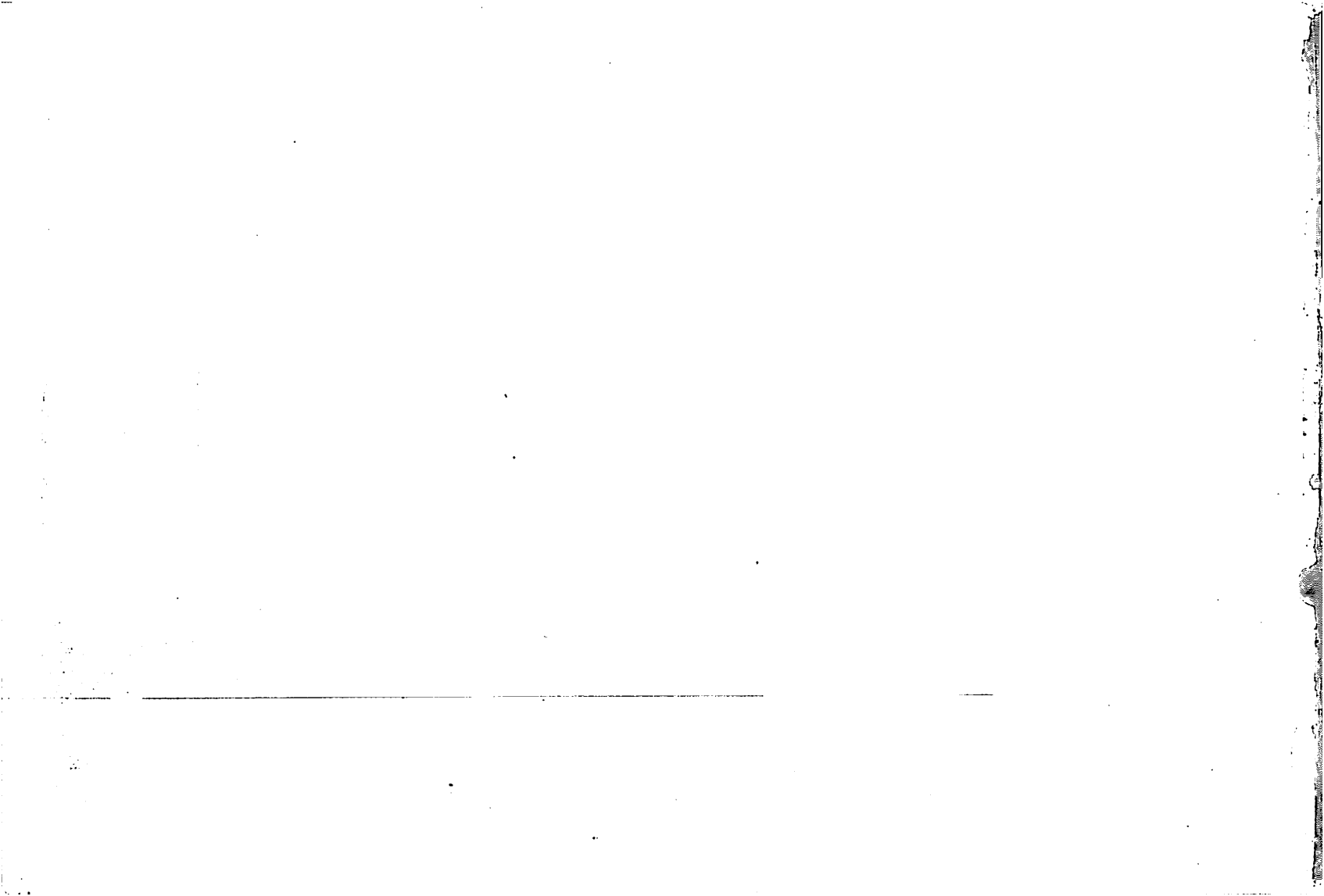

The water system in your Airstream trailer provides full service, both when city water is available and when the trailer is operated completely self-contained.

When you wish to operate your water system from a city water service, connect a hose to the water inlet fitting located under the rear roadside corner of the trailer just forward of the bumper. Since the system is completely automatic, nothing else needs to be done before you utilize the entire water system, except to turn the water pump "Off." This water pump switch is located on the CENTRAL CONTROL panel in the front roof locker.

If the water system has previously been drained, it will be necessary for you to force the air from the water heater before lighting the water heater. Open a hot water faucet and allow all of the air to be forced out of the water heater. The water heater capacity is 10 US gallons. If you plan to remain for some time where city water is available, drain the water storage tank and refill with fresh water before departing. Your system has check valves in the water lines to protect the water tank, therefore, it will not fill while you are connected to city water. To fill the water tank when the trailer is connected to city water, merely open the crossover valve and remove the filler cap from the water tank. **NOTE:** This valve must be kept closed unless you wish to fill your water tank from city water source. Your water system will not operate on self-containment with this valve open. While filling the tank through the crossover valve, removal of the filler cap will prevent the water tank from being pressurized from the city water pressure, which could rupture the tank. In models with standard pull-out front lounge, this valve is located adjacent to water pump. In models with Safari twin lounges, the valve is located under the access

panel in the front roadside corner of the trailer.

If city water is not available, or will not be available at your destination, the Airstream self-contained water system may be used. The lightweight polyethylene water tank stores 30 gallons of clean fresh water for all your needs. The Airstream pressure-demand water pump (must be turned on at CENTRAL CONTROL panel) runs whenever a faucet is open and shuts off almost immediately when the faucet is closed; silently delivering 3 gallons per minute under constant pressure. To fill the water storage tank, remove the filler cap and fill with a water hose or bucket, or through the city-water crossover valve as described earlier. The tank may be filled until the water entry pipe is overflowing. Replace the cap . . . the water system is now ready for use. Remember, if you have been hooked up to city water your tank will not have been filled, unless the crossover valve has been opened, so be sure to fill it before leaving.

To give complete access to the pump and the water screen, pull out the lounge, remove the filler mattress and (safari lounge only) lift off the loose plywood cover on the left hand side of the lounge.

NOTE: Before leaving your Airstream unattended for any length of time, it is advisable to turn off the water pump. (The switch is located on CENTRAL CONTROL panel.)

The water screen mentioned above should be cleaned periodically to prevent accumulation of dirt, sand, etc. The screen is located under the front lounge next to the pump. To remove it, disconnect the rubber hoses from both ends, separate the screen housing, and lift the screen out of the compartment.

WATER SYSTEM



Due to iron and lime deposits which are found in various parts of the country, it is advisable to clean the tank occasionally. Pour some bicarbonate of soda into the filler pipe with several gallons of water and allow to stand for several hours. Flush out by opening the drain valve and running cold water through the tank.

WATER PURIFIER (standard on International models).

Among many fine accessories for your Airstream is the Everpure EN-1 Water Purifier. This is located under the galley sink. It is designed to remove all dirt and colloidal matter and to eliminate all tastes and odors of chlorine, phenol and similar products, delivering a sparkling, taste-free water ideal for drinking, cooking, coffee, tea, ice cubes and carbonated water.

The purifier, by itself, is **NOT** guaranteed to remove tastes and odors or iron and sulphur, although in certain cases it does so. The best known method for removing sulphur tastes is chlorination of the water supply. This, of course, adds its own taste to the water, but the purifier will completely remove the chlorine after it has done its job. Super-chlorination will also precipitate dissolved iron which the purifier will then remove.

The quality of the water never varies. At the end of the filter pack life the quality of the water is just as perfect as when it started. The flow rate is all that changes. As the filter pack is used, the minute pores slowly fill up and the flow rate gradually decreases. When the rate reaches a point where it is no longer convenient for use, it is time for replacing the filter pack. These are available from your dealer or Wally Byam Stores. Instructions for changing the pack are in each box. It is a good idea to order packs two

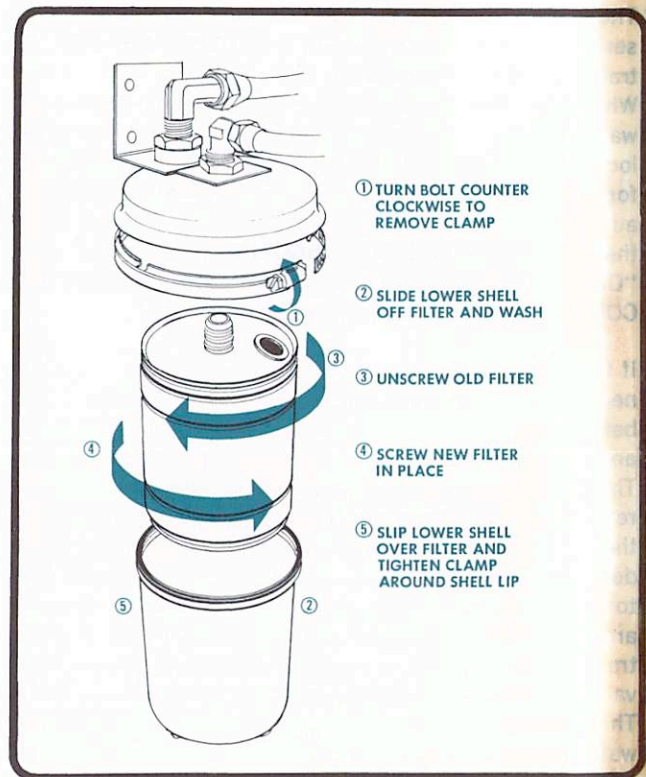

at a time so that you will always have a spare on hand. Your Airstream is equipped with a water pressure regulator which is located adjacent to the water inlet in the one-stop service center. This is an exclusive feature which protects the plumbing inside your Airstream from possible excessive pressures which may be encountered in some

city water systems. The water pressure regulator insures that regardless of variation in the city water pressure, the water pressure at the faucets in your Airstream will always remain constant. If it should ever become necessary to adjust the water pressure regulator there is a screw adjustment located on the dome. Turning this screw clockwise increases pressure, counter clockwise decreases pressure.

WATER SYSTEM TROUBLE SHOOTING.

TROUBLE — PUMP DOES NOT PRIME.

- a. Be sure there is water in the tank.
- b. Make certain battery power has not been exhausted.
- c. Make certain crossover filler valve is turned off and there is no air leak between the tank and the pump.
- d. Check valve assemblies to make certain no foreign matter is between the valve and valve seat causing loss of suction. This is done as follows:
 1. Remove four slotted head screws.
 2. Lift motor, drive and diaphragm assembly off base.
 3. Lift valve assemblies from pockets and clean all foreign matter from valve and valve seat.
 4. Replace valve assemblies back in the same pockets, being sure rubber valve is in UP on INTAKE SIDE and DOWN on EXHAUST SIDE.
 5. Replace top assembly and bolt back together, being careful to tighten evenly.

TROUBLE — PRESSURE DROPS AND PUMP KICKS ON PERIODICALLY WHEN WATER IS NOT BEING DRAWN.

- a. Check all connections and faucets for leaks. One drop of water per minute will cause pump to run every two hours.
- b. Same as d. above.

TROUBLE — PUMP OPERATION IS ROUGH AND MAKES EXCESSIVE NOISE.

- a. After several months of operation, under certain conditions, the flow of the pump may become rough. If this happens the flow may be smoothed out again as follows: Turn pump off. Remove BOTH inlet and outlet hoses from pump, place rags or sponges under both ports and turn on pump. Let pump run until all water is expelled from pump.

TROUBLE — EXCESSIVE BELT WEAR

- a. Adjust belt for proper tension. Belt has proper tension if it can be moved in and out on one side a total of $\frac{1}{4}$ " at a point half way between pulleys. To adjust belt: Loosen nuts on end of motor and slide motor up or down until desired tension is attained, then retighten nuts.

TROUBLE — PUMP RUNS FREQUENTLY OR CONSTANTLY AND THERE IS NO LEAK IN THE PRESSURE SIDE.

- a. Make sure crossover valve is turned off.
- b. Check for an air leak on the suction side of the pump (between the tank and the pump). This will not damage the pump but will run the battery down.

The water system schematic for your particular model Airstream is illustrated on one of the following pages. We suggest that you cross out the schematics which do not apply to your Airstream to insure future reference to the proper schematic.

For water system capacities, refer to chapter 15.

trouble shooting

WATER SYSTEM



water system
diagram

WATER SYSTEM

8

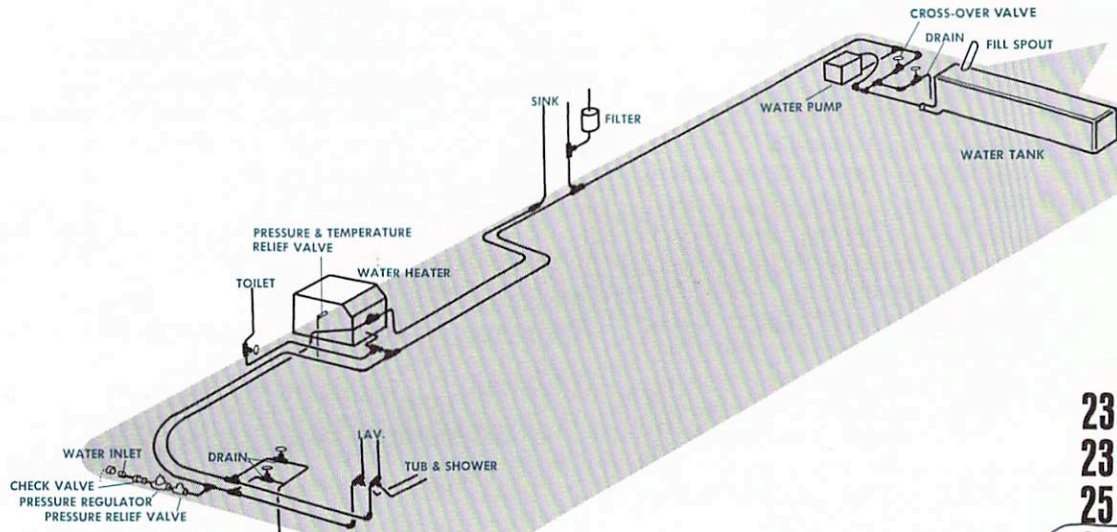

23 T
23 D
25 T
25 D
27 T (L.Y.)
27 T (INTL.)

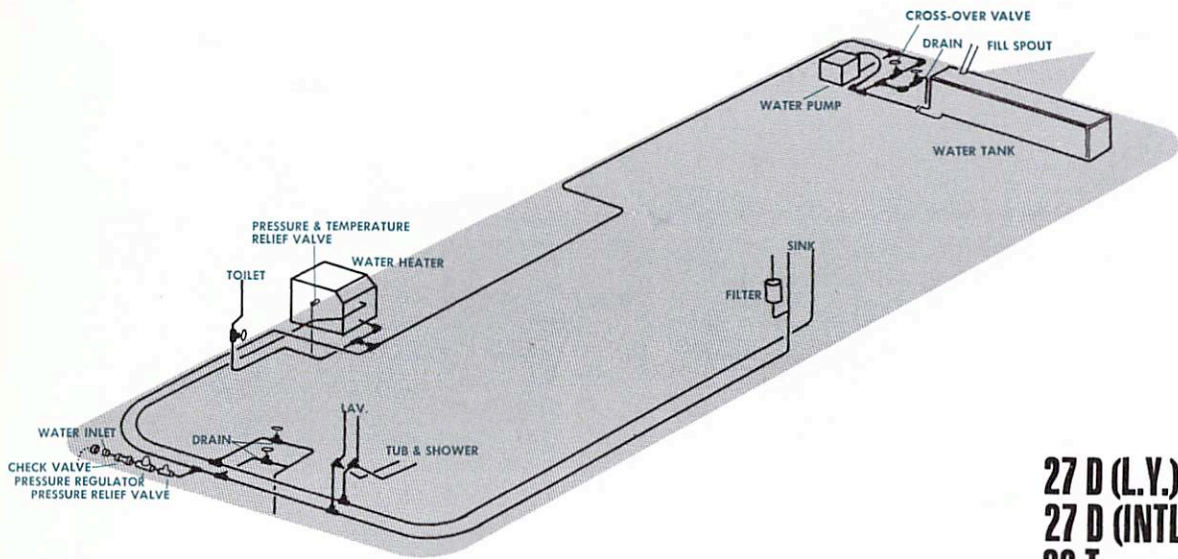

27 D (L.V.)
 27 D (INTL.)
 29 T
 29 D
 31 T
 31 D

water system
diagram

WATER SYSTEM





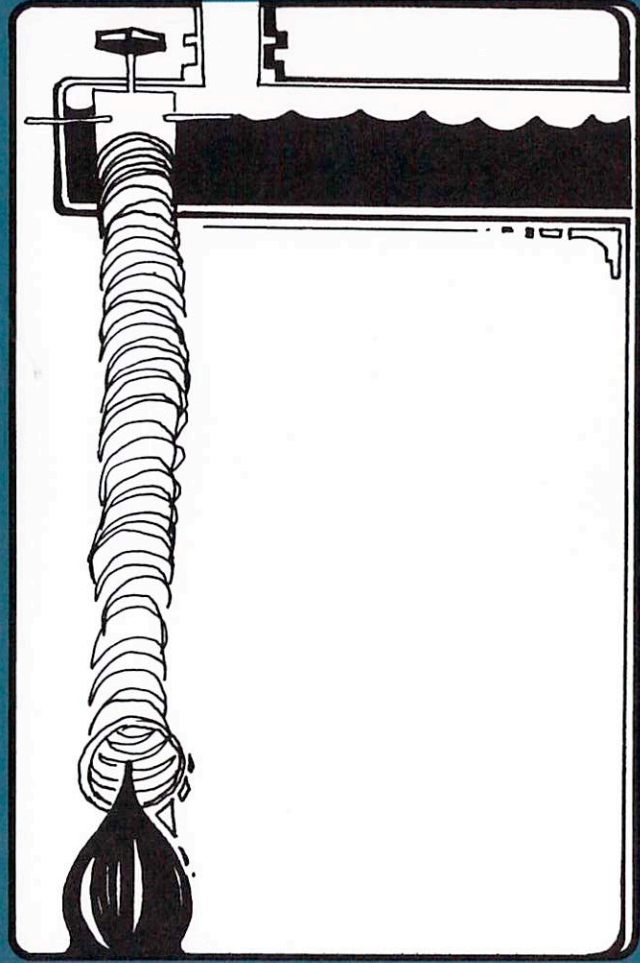

6

DRAINAGE SYSTEM



Your Airstream is equipped with a Drain, Waste and Vent system similar to the one in your home or apartment. It is also equipped with a waste holding tank for sewage which permits use of the toilet for several days away from disposal facilities. The waste water from the sink, the shower, bath and lavatory all drain through the same outlet as the waste tank, so you will need to make only one connection when hooking up in a trailer park.

The waste holding tank is made of seamless molded plastic completely free from corrosion problems, with a specially designed dump valve for trouble-free operation. When the toilet will no longer drain, the tank is full and must be emptied . . . watch this closely because when the tank is full the sewage cannot be emptied from the toilet bowl. To empty tank, attach sewer hose by pressing the bayonet-fitting onto the dump-valve outlet and rotate clockwise until it feels solid and secure. Attach the outlet end of the hose to the sewage outlet making certain that the hose is positioned so that it will drain completely. Pull up the dump valve handle as far as it will go and wait until the tank is drained. Close the dump valve and refill the tank with from 5 to 10 gallons of clean water and repeat the operation to insure that all paper and waste material has been flushed out. The sewer hose is stored in a compartment between the bumper and rear of trailer body. We recommend that you rinse out the sewer line before storing. A convenient fitting, for refilling or flushing tank, is located at the right side of the One-Stop service center. Be sure to replace the cap after using this fitting.

If you are moving on, place a small amount of clean water in your tank with some commercial cleaner, such as Pink Magic (available through the Wally Byam Stores), so that it will slosh around and clean the tank while you are driving.

HOW TO USE THE SYSTEM WHEN CONNECTED TO A SEWER LINE.

1. Use The Toilet On Automatic Flush.

The mechanism is designed to partially refill the bowl after each use with clean, fresh water and is as sanitary as the toilet in your own home.

2. Keep The Holding Tank Dump Valve Closed.

Empty the tank every few days or whenever it becomes almost full. The idea is to send a large volume of sewage through the tank and drain hose at one time. This practice sets up a swirling action and high currents which floats the toilet paper and other solids completely away.

3. Avoid Accumulation of Solids.

It is very poor practice to keep the tank valve open or partially open when connected to a sewer or gopher hole. It is not like a home toilet where a large volume of water is used at each flush. There is usually not enough liquids to float all of the solids in a single flush. In time this builds up into trouble. The end result can be a disagreeable cleaning job. Should this ever happen, the best method of cleaning the tank is to close the valve, fill the tank about half full of water, and then tow the trailer for a few miles. The turbulence and surging of the water will usually dissolve the solids into suspension and the tank can be drained. You can add a little soap or tank deodorizer (Pink Magic), but nothing else. **(Do not add detergent.)**

HOW TO USE THE SYSTEM WHEN PARKED WITHOUT A SEWER LINE CONNECTION.

1. AUTOMATIC FLUSH.

When traveling and you anticipate finding a dumping station, or being connected to a sewer line every few days, you can use the toilet on automatic flush if you wish. It

sewer connection
self contained

DRAINAGE SYSTEM





uses very little water. The holding tank will provide space for the requirements of two adults for two to four days, or longer. As long as you are traveling in the United States or Canada you usually do not have to worry about your fresh water supply as it is readily available almost anywhere. Pressure or hand refill of your fresh water tank is seldom a problem. If you are traveling in areas where water is scarce, use the hand spray flush.

2. "WATER SAVER" HAND SPRAY FLUSH.

The proper use of the hand spray makes it possible to flush the toilet with a very minimum of water; thus stretching your holding tank over a long period of time. This makes it possible to stay a week (or weeks) in faraway places or crowded areas where there are no sewer line connections.

2a. How To Flush For Urine Only. The least possible use of water is accomplished by very slightly spraying the inside of the bowl, making its surface wet with clean fresh water. After use, the prewet bowl is very easily sprayed clean with less overall water than starting with a dry bowl.

2b. How To Flush For Urine And Feces. Spray just enough water in the dry bowl to provide for flotation of paper and solids. After use, rinse down the sides with the hand spray and empty the bowl. Hold the slide valve open and spray and rinse the lower surface. Even if it appears clean, give it a once over quick rinse. Then let up on the pedal. The toilet is now ready for the next use.

THE TOILET.

The toilet in your Airstream is an Aqua-Magic Supreme designed expressly for travel trailers. It is warranted for two years against defects in materials and workmanship. The Aqua-Magic Supreme employs a completely new principle:

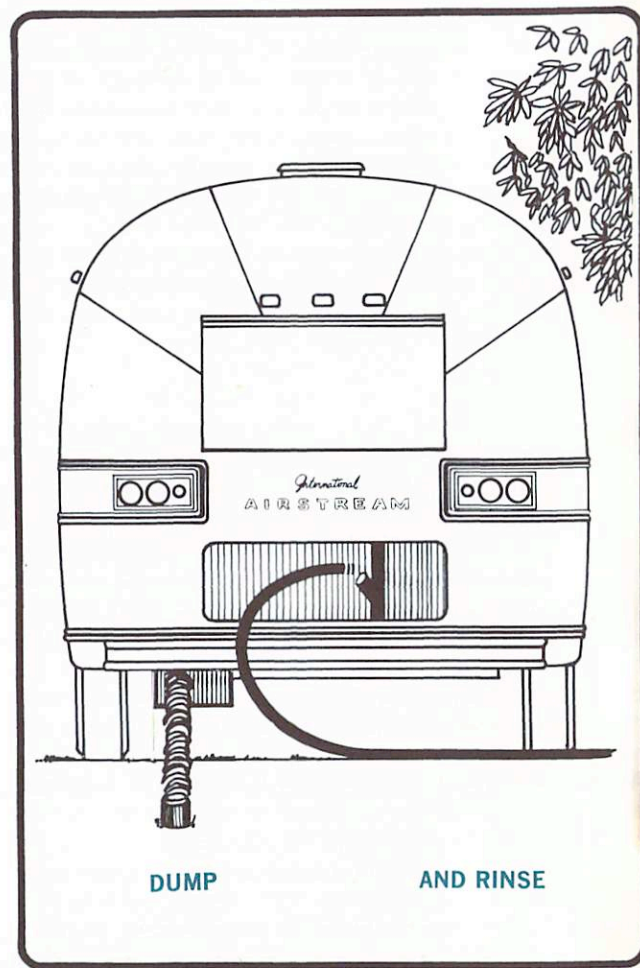

a sliding self-cleaning positive seal blade, which replaces the conventional clapper valve. Odors cannot escape from the holding tank into the interior of the trailer. No metal parts come in contact with the sewage; no mechanical adjustments are necessary; there are no cavities or clearance chambers to become fouled. The unit uses less than two quarts of water for automatic flush. A special feature of the Aqua-Magic Supreme is the second pedal attached to the main foot pedal. Depressing this pedal allows you to introduce water into the bowl through either the fill rim or hand spray without opening the slide valve.

DIRECTIONS FOR AUTOMATIC FLUSH AND REFILL.

1. Step on foot pedal. This opens slide valve and drops waste into holding tank.
2. Hold pedal down until water begins to swirl. This fills rim storage and rinses the bowl.
3. Release foot pedal. This closes slide valve blade and stops usage of fresh water. Bowl refills automatically.

DIRECTIONS FOR "WATER SAVER" HAND SPRAY FLUSH.

1. Hold hand spray in ready position over bowl.
2. Depress thumb button. This prepares for the blast of water used to clean the bowl.
3. Step on foot pedal. This dumps the contents of the bowl. It also sends fresh water through the hand spray.
4. Spray bowl clean.
5. Release foot pedal. This shuts off all flushing water flow.
6. If you wish to refill bowl with water for next use depress small foot pedal until water reaches desired level.

NOTE: If the thumb button is released before the foot pedal is released, water will automatically begin to flow

through the rim of the bowl. No water can enter the rim of the bowl as long as the thumb button is depressed.

USING A "GOPHER HOLE."

When you are parking in areas where it is permissible to do so, you may dig a "gopher hole" to dispose of the contents of your waste holding tank.

Dig a "gopher hole" as follows: Dig a hole from 18 to 20 inches in diameter and 40 inches deep, keeping the dirt you dig out in a large carton or box under your trailer. After the hole is dug, back your trailer up so that the toilet drain hose will drop straight down into the hole and so that the hole will not be where anyone could step into it by mistake. It is strongly recommended that you use an Airstream "gopher hole" cover . . . a plate which will cover the hole completely and that you can seal by piling some

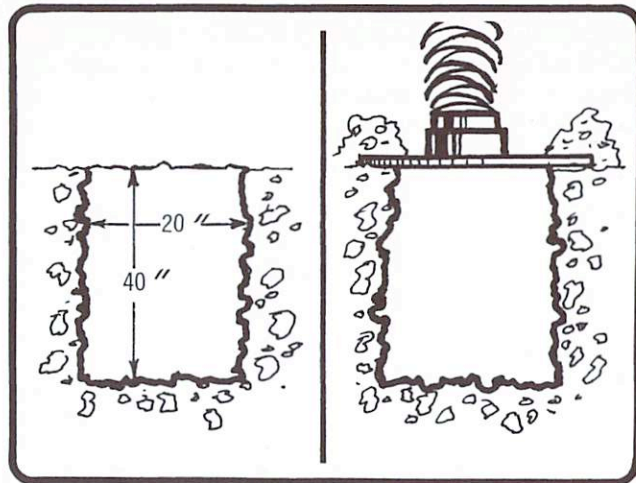



dirt around the edges (the hole in the plate will be just large enough to take the sealing ring you usually use to seal your sewer hose where it enters the trailer park sewage system). Drain your holding tank the night before you leave; the ground will absorb most of the contents overnight and it will be much easier to fill in just prior to departure next morning.

Beware that rain surface runoff water does not drain into your gopher hole and cause overflow. Mound some dirt around the hole to avert this.

THINGS NOT TO PUT INTO THE TOILET AND TANK.

FACIAL AND OTHER SIMILAR TISSUES.

Unlike toilet paper, nearly all facial tissues are impregnated and treated to give them wet strength. This quality makes it almost impossible to dissolve them in the tank. Most toilet papers dissolve after a period of time, especially if agitated by traveling.

DETERGENTS AND BLEACHES.

It is a fairly common practice to use detergents and bleaches as a deodorizer, but this can only harm the operation of the tank by removing lubricating oils and greases. It is far better to use a trailer sewage tank deodorizer which you can obtain from the Wally Byam Store or your dealer.

ANTIFREEZE, AMMONIAS, ALCOHOLS, AND ACETONES. Such liquids as those above and solution which contain these chemicals may cause damage to your tank, valve parts, tank fittings, or drain hose. For protection against freezing, refer to chapter 12 on winterizing your trailer.

DISHWATER AND WASHWATER.

Nearly all kitchens and laundry soaps contain detergents which attack the lubricants, and should not be dumped into the tank. Some state and federal parks prohibit draining sink and bath water onto the ground, although it is often done in the wilderness.

Although we do not recommend the following practice for reasons stated above, in an emergency, you may empty waste water from the sink and lavatory into your waste holding tank instead of allowing it to drain onto the ground. To empty waste water into the waste holding tank, open the dump valve while keeping the sewage line drain cap on. Waste water will automatically back up into the tank. **Note:** Water conservation must be practiced as holding tank will fill rapidly. After you have been draining waste water into the holding tank and wish to drain the holding tank, place a bucket under drain outlet, **close the tank dump valve** and remove the drain outlet cover cap. This will drain the section of pipe between the cap and the valve and any adjacent drainage lines that might have filled with waste water. Next, drain the holding tank following the instructions at the beginning of this chapter.

While holding tank is draining we recommend you flush all drain lines by running water into the tub/shower, lavatory and sink.

The drainage system schematic for your particular model Airstream is illustrated on one of the following pages. We suggest that you cross out the schematics which do not apply to your Airstream to insure future reference to the proper schematic.

For capacities of holding tanks, refer to chapter 15.

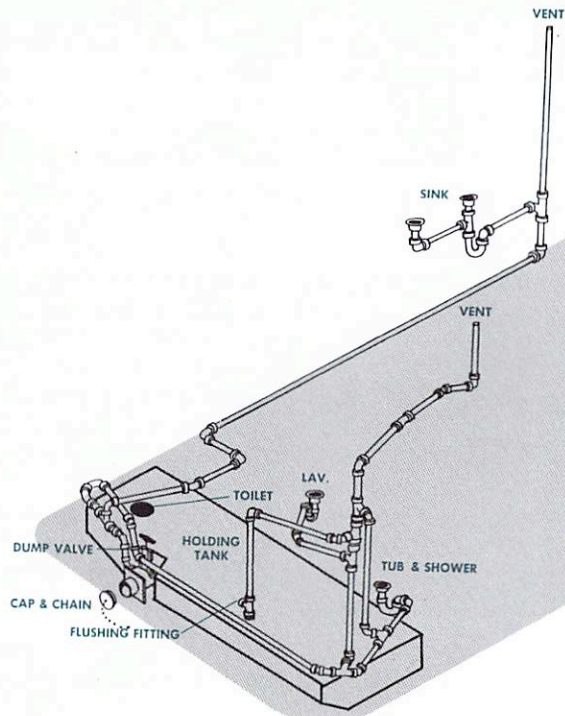

- 23 T
- 23 D
- 25 T
- 25 D
- 27 T (L.Y.)
- 27 T (INTL.)



drainage system diagram

DRAINAGE SYSTEM

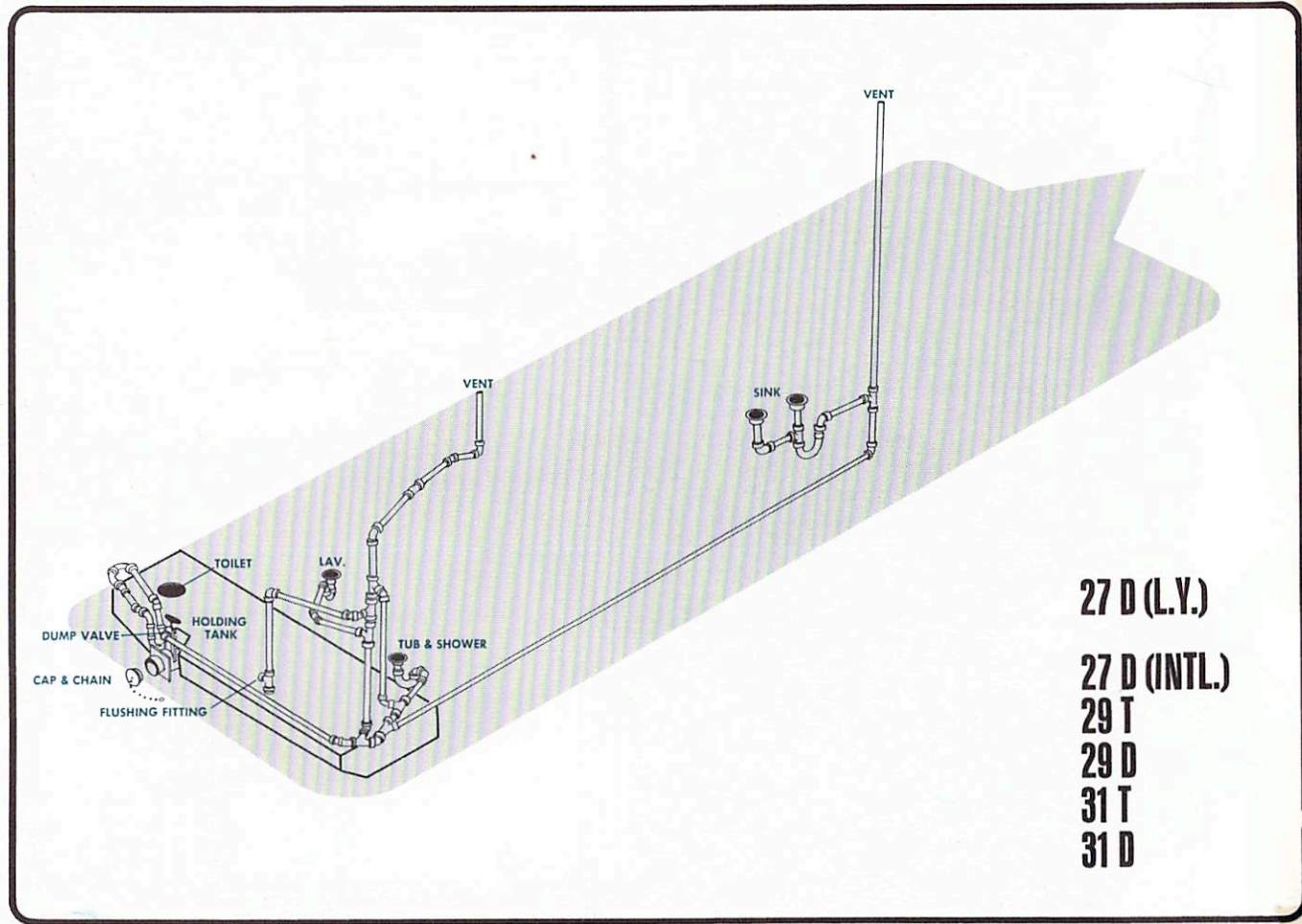

27 D (L.Y.)

27 D (INTL.)

29 T

29 D

31 T

31 D

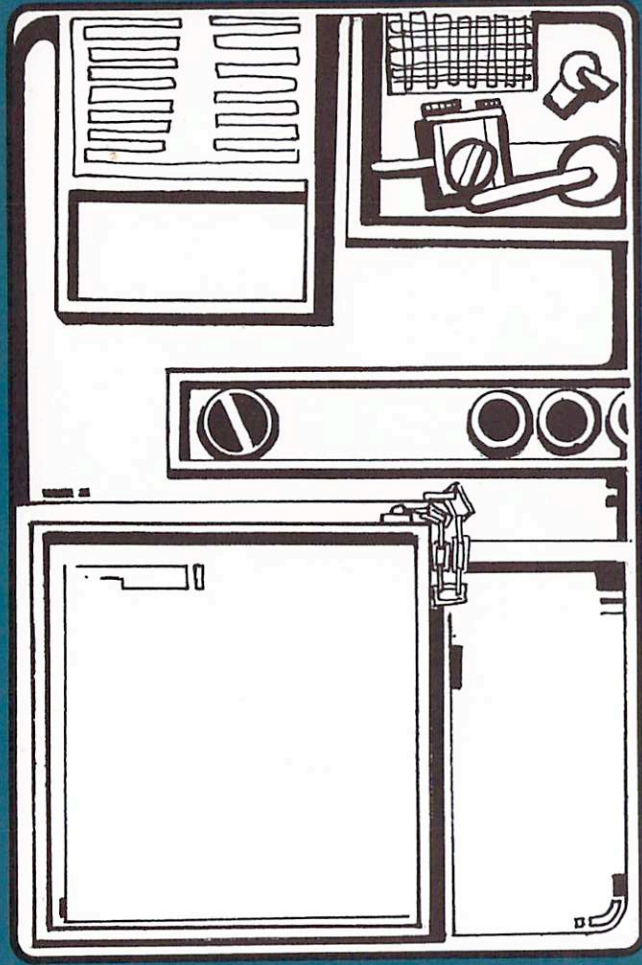

APPLIANCES

10

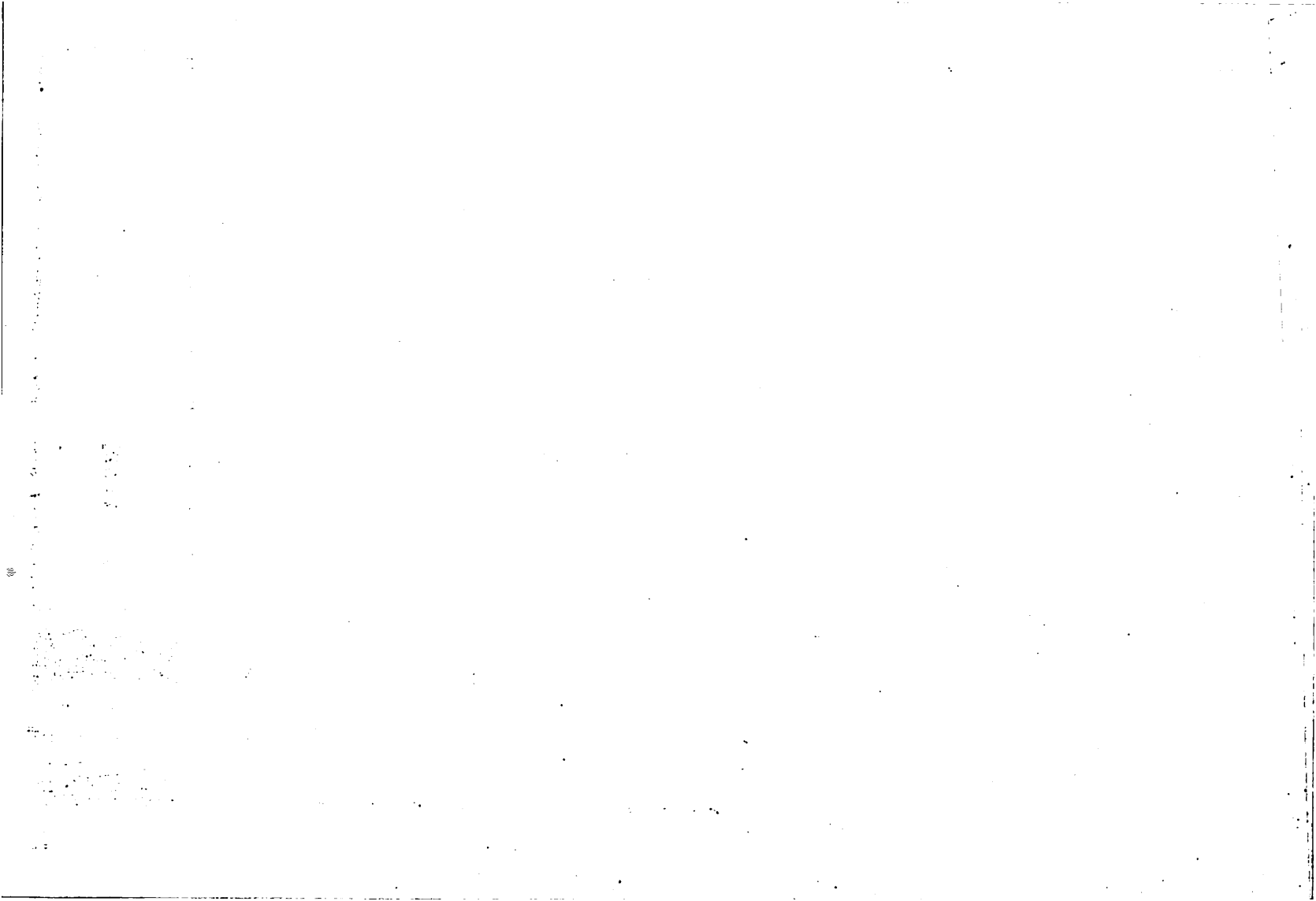

This chapter will review the operation of the various appliances furnished with your Airstream. Appliances which are an integral part of a system (such as the toilet is part of the drainage system) are discussed in chapters on that particular system.

THE FURNACE

The furnace in your Airstream is a Suburban sealed combustion system furnace approved by the American Gas Association, for safety and performance, for installation in travel trailers. This furnace utilizes a sealed combustion system with a patented dual blower. One blower circulates room air while the other furnishes outside air for combustion. The combustion air blower then forces the flue products to the outside for maximum safety and heating efficiency.

The unit incorporates an advanced design for circulating the warm air. All trailer models have registers located near both ends of the trailer. These are heat registers; their function is to circulate warm air. The register which serves the living room area has adjustable louvers. Return cold air for the furnace is drawn through openings in galley cabinet toe kick.

During freezing weather, to insure that the water tank does not freeze, leave open the doors under the front lounge. This will allow additional warm air to circulate around water tank. The heat duct system incorporates a special duct which feeds warm air around the holding tank and one stop service center, as this area contains a great deal of water and drainage lines.

OPERATION (see figure on this page).

If the furnace has just gone out, turn the manual gas valve

off and wait five minutes before attempting to relight the pilot. Set the thermostat to the OFF position. Open the latch on the furnace door and raise the door. Turn on the manual gas valve and depress the reset button (P) and hold. Light the pilot by pressing in quickly with a pumping action on the ignition button (I). After the pilot is lit, keep the reset button depressed for thirty seconds. Release the reset button (P) and the pilot should remain lit. If the pilot goes out, repeat the above operation and keep the reset button depressed for a longer time. Close the front access door.

Set the thermostat at the desired temperature. **NOTE:** The pilot may not light immediately due to the air in the gas line. If such is the case, it may be necessary to hold the reset button (P) in for a minute or more before the pilot ignites.

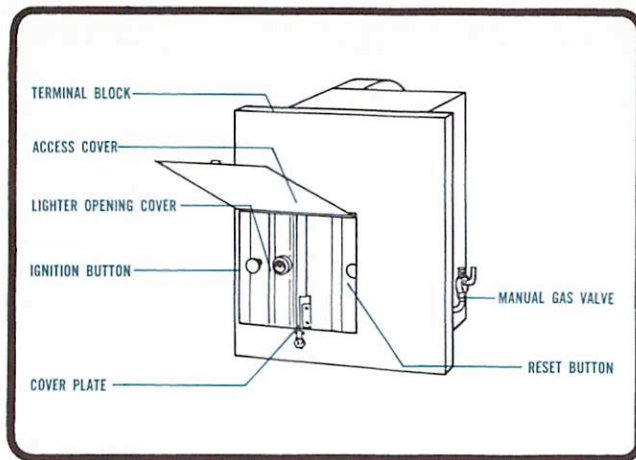

Lighting the furnace with a match or a gas-lighter can be accomplished by opening the front access cover, removing the lighter opening cover and lighting the pilot (using the reset button as mentioned before). In isolated cases, it may be found that the difference in pressure between the air in the room and the air outside the trailer will cause a strong draft through the heater when the light opening cover is removed, resulting in a difficult lighting operation. When this condition exists the pressure may be equalized by opening a window or door, as near as possible to the heater. The desired result may not be obtained unless the door, or window is on the same wall as the heater. After the pilot has been lit and the lighter opening cover replaced, this difference in pressure will not effect the operation of the heater. Close the front access door and set the thermostats to the desired temperature.

ADJUSTMENT OF MAIN BURNER (Primary Air).

The heater should be set into operation by advancing the thermostat and should be allowed to run for at least 10 minutes, or until it reaches near-maximum operating temperature. Observation of the main burner may be done through the lighter opening cover. The flame should be without a trace of yellow and be "sitting" on the burner. Since the heater is tested at the factory before shipment, it may be found that the primary air is already in proper adjustment. NEVERTHELESS, IT IS RECOMMENDED THAT THE ADJUSTMENT PROCEDURE BE CARRIED OUT. The burner adjustments may vary from one location to another due to the difference in elevation as well as the difference in the characteristics of the fuel gases.

If the flame burns yellow or "lifts" off the burner port, the primary air needs adjustment. To adjust the primary

air, raise the front access cover and take out the screws that retain the rectangular cover plate (see figure on page 87). Inside the opening, created by removing the cover plate, is a threaded rod with the visible end slotted. This rod controls the position of the main burner air shutter. With a screw driver, turn the rod until the flame sits on the burner. The air shutter should be adjusted to the point where a slight trace of yellow remains in the tip of the flame. Final observation should be made with the cover plate in place, at which time the yellow tips should have disappeared. **CAUTION:** It should be remembered that the lighter opening cover and the primary air adjustment cover plate must be in place for proper operation of the furnace.

SEQUENCE OF NORMAL OPERATION.

When the thermostat calls for heat, the blower is energized immediately. As the blower reaches approximately 75% of full speed, a microswitch will engage, opening the solenoid valve, and thus turning on the main burner. If within a period of approximately two minutes after the main burner is lit, the thermostat is turned back, both the motor and solenoid valve are de-energized. However, if the heater is allowed to operate longer than the period of approximately two minutes, a slight snap can be heard from within the casing. This snap is caused by the fan switch as it changes its position. After this occurs, if the thermostat is turned back (or when the thermostat is satisfied), the solenoid valve will close, the flame on the main burner will go out, but the blower will continue to run. The purpose of this is to remove most of the remaining heat from the heater as well as force the combustion gases from the heat exchanger. The blower will continue to run for a short time and will then shut off. It is perfectly normal

for the blower to continue in operation for a time after the burner is off. To turn off the heater, turn the thermostat to its OFF setting and turn the manual gas valve to its OFF position.

The furnace fan can be used to circulate air during hot weather simply by turning the thermostat up to a setting higher than the temperature in the trailer. However, be sure you always turn the thermostat to the OFF setting whenever the heater is not in use. Otherwise during cool evenings the fan might turn on and run your battery down.

REMOVING MOISTURE.

When humidity is high inside your trailer, turn on the trailer exhaust fan in the roof vent or open a roof vent if you do not have a fan and open a window slightly to get cross ventilation. This will not affect the operation of the furnace.

TROUBLESHOOTING.

If the heater does not perform normally, the following list of some of the most probable causes and their corrections will be helpful in an emergency situation. Normally, this type of servicing should be done by your dealer.

If cool air is constantly discharged while the blower is in operation, it is obvious that the main burner is not on. This condition is caused by one or any combination of the following:

1. Pilot outage.
2. Defective microswitch.
3. Defective limit control.
4. Defective fan switch.
5. Loose connection in terminal block.
6. Defective solenoid valve.
7. Low supply voltage.
8. Out of fuel.

PILOT OUTAGE.

Pilot outage is the most common cause of failure. It is

found that the pilot will not stay lit unless the reset button is depressed, a series of checks may be performed to quickly determine the cause.

The trouble is most likely in the thermocouple. First, check to see that the end of the thermocouple lead is screwed firmly into the safety pilot valve and the joint is clean. If this is not the cause, the burner assembly should be removed. A visual inspection of the thermocouple may show that it is defective. If the copper sheath of the lead is broken or if the thermocouple tip shows signs of being bent or ruptured, it should be replaced with a new part. The new part must be of the same part number as the old one, or it may not fit or function properly. Replacement parts are available through any Certified Service Center.

Sometimes a safety pilot system will hold part of the time but will drop out during operation of the heater. This is commonly caused by either a weak pilot, a weak thermocouple, or a weak power unit in the safety valve. A simple but very effective check can be made to detect such a condition. Light the pilot and allow it to burn for two or three minutes; then blow it out. Using a watch with a second hand, measure the time required for the safety pilot valve to drop out. (This drop out is evidenced by a clicking sound from the safety pilot valve.) The time should not be less than 30 seconds. If it is, we recommend that a service representative be consulted.

In the case of low pilot flame, where the thermal element is not bathed in flame, the pilot may be too low. This is caused by either a partially stopped-up pilot orifice or pilot line, or possible a partially blocked passage in the safety pilot valve.



A common cause of pilot failure, especially on LP gas, is in the failure or freeze-up of the pressure regulator located on the gas bottles. If only enough gas to supply a pilot flame is being drawn through a regulator, it could and sometimes does allow higher pressures to build up. This may be for only a short period of time and for that reason it is often hard to detect. This condition is evidenced by a blue flame which is blowing hard. If such is suspected, it is recommended that the regulator be checked and adjusted. If the pilot should fail during operation, the cause could be that either the controls compartment cover or the base of the blower assembly is not properly secured. This condition is evidenced by a "floating" main burner flame and sometimes by a strong undesirable odor from the heater.

DEFECTIVE MICROSWITCH.

The microswitch operates in response to the current of air generated by the blower. Hence, if for any reason the air from the blower is not sufficient, the microswitch will not operate. This may be caused by dirt accumulation in the blower wheels or by damage or dislocation of the cabinet insulation so as to block passage of air. If the switch is activated by the air but still fails to operate, it should be replaced.

DEFECTIVE FAN SWITCH.

The purpose of the fan switch is to control the sequence of operation of the blower. In the cold position the contacts are closed. This allows current to be supplied to the motor through the thermostat. When the combustion chamber heats up, heating the element of the fan switch to the operating temperature, the switch changes position to complete a circuit through the motor from a direct source.

Because of this, the blower will continue to run as long as the combustion chamber is hot, even though the thermostat is satisfied. If blower performance is other than described, or if the snapover in either direction causes even the slightest interruption in the normal hum of the motor, the control should be replaced.

DEFECTIVE LIMIT CONTROL.

The purpose of the limit control is to turn off the gas to the main burner if for any reason the heater becomes excessively hot. Improper operation of the heater due to the limit control does not always indicate a defective control. If the circulating air is blocked or only partially so, the limit control will function and cause the main burner to cycle. Cycling on the limit is not always undesirable — if it happens only occasionally. This is a good indication of safe operation and will sometimes happen on a cold day. If cycling happens too often or for an extended period, it indicates insufficient movement of air through the system. Check to be sure that the front louvers are not closed. If cycling persists, it may be necessary to clear the heat ducts. If for any reason the limit control is found to be defective, there is no recommended method of repairing it. Because of its importance for safety reasons it should be replaced with a new one. **CAUTION: NEVER BYPASS THE LIMIT CONTROL EVEN FOR TEMPORARY OPERATION.**

LOOSE CONNECTION IN TERMINAL BLOCK.

If the heater does not function as described under "Sequence of Normal Operation," a likely source of trouble is in a loose electrical connection. All wiring is furnished with a pressure-type terminal. The ends which engage with the terminal block are of the friction type and must be

pressed securely into the opening of the block. In most cases the trouble is quickly located and corrected.

DEFECTIVE SOLENOID VALVE.

Any evidence of improper performance may be checked by applying voltage directly to the leads. This voltage should, of course, correspond with the furnace rating plate data.

POWER SUPPLY.

The furnace operates from a 12-volt DC power supply. On self-containment as the battery voltage drops, the blower circulation will decrease until the microswitch in the blower finally "drops out." This condition prevents the furnace from operating until the rated battery voltage is restored.

THE REFRIGERATOR.

Your Airstream is equipped with an A.G.A. approved Dometic gas-electric refrigerator. These are the finest refrigerators available for travel trailer use and will give you many years of faithful service. Whenever you park your trailer, care should be taken that it is level for best operation of this refrigerator. When parking try to avoid having a strong wind blowing directly against the vent outlet for most efficient operation.

The figure on this page is an illustration of the working parts of your refrigerator which will be referred to in the following operating instructions.

FOR GAS OPERATION

The gas tap must always be fully opened whenever the refrigerator is in use. A partially opened tap effects no saving and may interfere with the operation of the unit.

To light — Open kick plate on bottom front of refrigerator by pulling outward.

1. Before the Refrigerator is started on gas, check that the switch lever (F) is in off position. Turn gas valve handle (A) to open position and turn thermostat knob (B) to setting (4).
2. Press red button (C) of the automatic pilot and after about 15 seconds turn the lighter rod (D) clockwise with a rapid movement. This will create a spark which lights the burner.
3. After the burner is lit, keep the button (C) depressed for an additional 15 seconds.
4. Release the button (C) and check that the burner is operating. If not, repeat the lighting procedure.

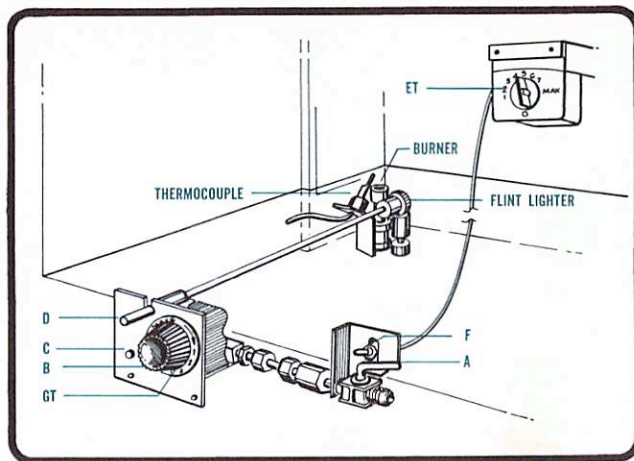

Incorporated in the burner bracket is an automatic flame failure device which allows gas to pass only when the burner is lighted, keeping the thermocouple hot. Should the flame be blown out, the thermocouple will cool and the device will cut off the flow of gas to the burner.

IMPORTANT: Always make certain that electric switch "F" is off before operating the refrigerator on gas

FOR ELECTRIC OPERATION

1. To start the refrigerator, turn the gas valve (A) to the shut-off position.
2. Check to be sure the electric cord is plugged into 110-volt outlet (at rear bottom of refrigerator). Turn the switch lever (B) to "on" position.
3. Turn the electric thermostat knob (C) to setting 4.

THE THERMOSTAT.

This refrigerator has automatic thermostatic control of the temperature in the food storage space. The gas thermostat (GT) controls the temperature during gas operation, while the electrical thermostat (ET) controls the temperature during electric operation. Be sure to make the temperature setting on the correct thermostat.

As soon as the required cold temperature inside the cabinet is reached, the thermostat cuts the burner main flame to the by-pass flame sufficient to keep the safety valve open during gas operation. During electric operation the thermostat cycles the flow of electrical current to maintain the set temperature.

DEFROSTING AND CLEANING.

Excessive formation of ice on the evaporator reduces refrigeration efficiency. It is, therefore, necessary to defrost the unit whenever ice has accumulated.

When defrosting is necessary, turn the thermostat (ET or GT) to warmest position and leave the door of the refrigerator

open. See that the drip tray is in position below the evaporator.

This is a good time to remove all food and clean the interior and all other plastic parts with warm water adding detergents. Never use abrasive or caustic cleaning powders, polishes, cleaning paste or any gasoline, turpentine and the like.

Use a damp cloth for cleaning and finish with a soft dry cloth. After the defrosting has been completed, turn the control knob to its normal position.

When the refrigerator is to be out of operation for some time, always leave the door slightly open or place a pie tin with some barbeque charcoal on the shelf.

TROUBLE SHOOTING (GAS OPERATION)

For emergency only—this normally should be done by dealer.

TROUBLE: Flame is noisy with buzzing sound.

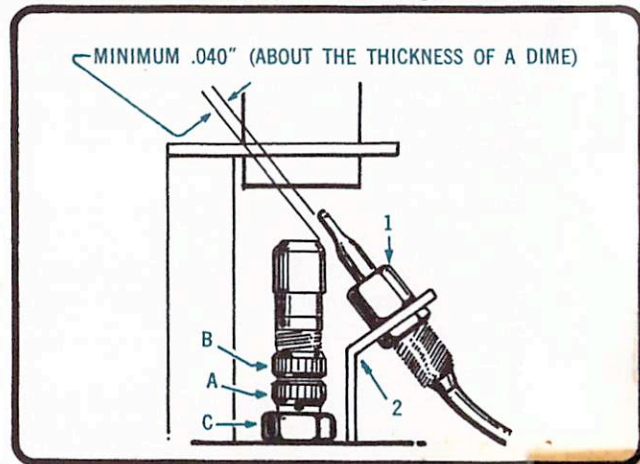

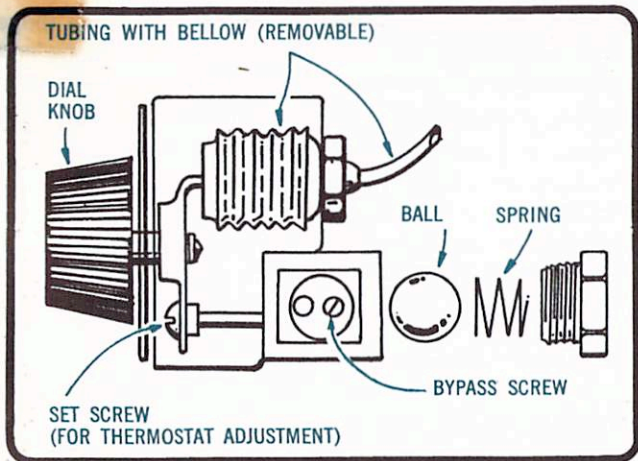

Causes and Remedies. a. Burner is getting too much air. Screw down the lower ring "A" on the burner to partially cover the air holes at the base, until the noise stops (figure on page 92). Lock in position with the upper ring "B." Make certain that the flame remains blue. Blocking the air holes "C" completely will cause the flame to become yellow and to smoke.

TROUBLE: When lighting the gas flame it goes out as soon as the push button is released.

Causes and Remedies. a. The thermocouple tip may not be in the flame. The thermocouple should be at an approximate 45° angle to the burner (See figure on page 92).

TROUBLE: Flame goes out.

Causes and Remedies. a. Flame blow-outs can be caused by excessive wind. If there has been no wind to cause the flame to repeatedly go out, go to a Certified Service Center

to have the thermocouple and safety valve checked.

TROUBLE: Overfreezing.

Causes and Remedies. a. The thermostat sensing tube is incorrectly located in the pocket inside the ice making compartment. Push the tubing back as far as it will go. b. The thermostat is out of adjustment. To adjust it turn the dial to "zero." If the flame does not go down to the "low" by-pass setting, follow this procedure (see figure on this page).

1. Unscrew the large cap screw at the rear of the thermostat and remove the ball. Clean seat and ball and replace.
 2. If procedure (1) does not correct the problem, remove the dial knob with the dial plate and turn the exposed set screw out (in counterclockwise direction) until the flame goes down to the by-pass (see figure on this page).
- c. If the flame keeps going out when the dial is turned to (0), remove and clean the by-pass screw which is located inside the gas connection on the left side of the thermostat.

TROUBLE: Burner does not light.

- Causes and Remedies.** a. Remove and clean burner barrel. b. Check gas supply.

ACCESS DOORS.

The small door on the side of the trailer behind the refrigerator is for access to the refrigerator elements for maintenance and service. They provide access to clean and service the burner, to clean the burner flue stack, and to perform other forms of maintenance and service. The doors are opened by unlocking and turning the handle approximately 1/4 turn counterclockwise.

THE RANGE AND OVEN.

Your Airstream is equipped with a Magic Chef gas range and oven. Following are some hints on how to keep them operating at their best.

RANGE TOP.

1. Your range is equipped with coaxial orifices for use with LP gas. The flame will be approximately $\frac{1}{2}$ inch long. Do not attempt to adjust gas to burner. The orifices have no adjustment.

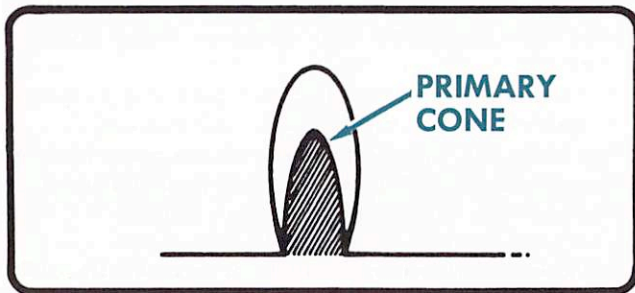

2. Air shutters on top burners are to be adjusted so that each cone of the flame is separate and distinct and appears as illustrated in figure on this page. Air shutters set too far open will cause flame to lift away from burner head and will be difficult to light. If air shutters are closed too much, the flame will look hazy and the distinct cones will be missing.
3. On 23, 25 and 27 foot LAND YACHT models, adjust the top pilot so that the tip of the flame is just over the edge of the inner cone. The burners should light within 4 seconds. If lighting is difficult, refer back to the previous step.

4. Never allow the top cover to be closed while the range is in operation, as this will extinguish the flame and permit the gas to escape into the trailer.

TROUBLE SHOOTING.**TROUBLE: Flames lift off ports.**

Cause: Too much air. Remedy: Decrease air.

TROUBLE: Soot formations.

Cause: Not enough air. Remedy: Increase air.

TROUBLE: Flame flashes back into air mixture chamber.

Cause: Too much air in proportion to gas. Remedy: Slightly decrease air.

TROUBLE: Orange flame.

Cause: Small filings in new burners or dust in air. Remedy:

TROUBLE: Burner fails to light.

Cause: Usually too much air. Remedy: Decrease air.

OVEN SECTION (Refer to figures on page 95).

IMPORTANT: Your oven is equipped with a safety ignition that requires a minimum of 30 seconds to operate after turning oven control knob (F) on. The oven pilot may be slow in lighting due to air in gas lines.

The automatic oven burner pilot in your oven consists of a constant pilot and a heater pilot. The small constant pilot (A), which should be burning at all times when parked, ignites the heater pilot (B) adjacent to the oven burner (C).

1. **To adjust the constant pilot (A):** Open shut-off valve (D), open pilot valve (E), light constant pilot (A) with match and by adjusting pilot valve (E), reduce flame on constant pilot (A) until yellow tip disappears.
2. **To adjust the heater pilot (B):** Turn control knob (F) to 300 degree temperature setting. This will permit gas

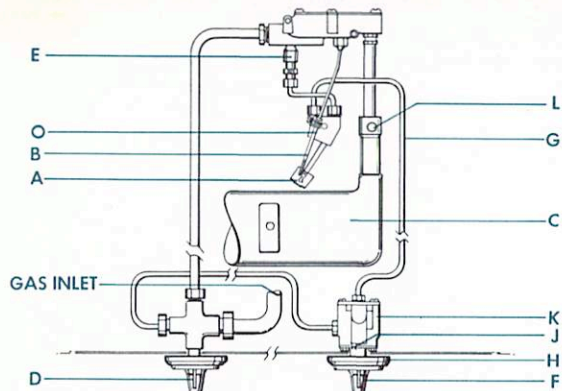

OVEN CONTROLS
MODELS 27, 29, 31 FT. (INTL.)

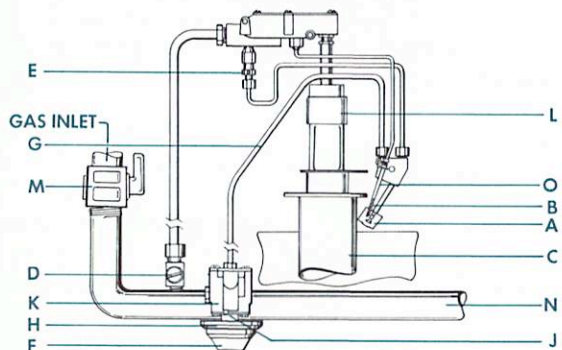

OVEN CONTROLS
MODELS 23, 25, 27 FT. (L.Y.)

to flow through the heater pilot tube (G) to the heater pilot (B) where the gas is ignited by the constant pilot (A). Remove control knob (F) and bezel (H) and open heater pilot gas supply by turning green heater pilot adjusting screw (J) on front of control valve (K) until flame on heater pilot (B) yellows. Now close adjusting screw (J) until yellow tip disappears. See that flame envelops temperature responsive element (O). Replace bezel and control knob.

3. **To adjust main burner:** Your oven is equipped with a coaxial orifice for use on LP gas. The main burner when adjusted to the proper rate will have a flame approximately $\frac{3}{8}$ inch long. The air shutter (L) on the main burners should be adjusted so the cone of each flame is separate and distinct (see figure on this page).

IMPORTANT: The thermostat on your range does not have a by-pass setting. It will cycle off and on at all temperature settings. No by-pass adjustment is necessary.

CLEANING INSTRUCTIONS AFTER RANGE IS IN USE.

1. To assist in cleaning the area around the top burners, the main top has been hinged from the back so that it can be raised. On 23-ft. through 27-ft. L.Y. models, care should be taken during the cleaning operation that you do not touch the hot pilot shield, and also when the cleaning operation is completed, be sure that the flash tubes are back in place.
2. If top burner heads are cleaned with any cleaning compound, care should be taken to see that all ports are opened up with a toothpick to assure proper operation. It is especially important that the lighter ports on the side of the burner head are kept clear (23-ft. through 27-ft. LY models only).



3. Spill over or spotting in oven or broiler are more easily removed when done promptly after they occur. Never wash porcelain when warm. Never use cleaning powder containing grit or acid.

If oven bottom is removed for cleaning or servicing, be sure that oven bottom is locked in place when it is put back in the range. The front return flange on the oven bottom must hook under the side support angles to prevent warpage.

NOTE: On 23-ft. through 27-ft. L.Y. models, the range gas line shut-off valve (M) located under the top of the range at the left end of the manifold pipe (N) must be turned off when towing the trailer, when changing the gas tanks, or if the gas supply is turned off for any reason. Be absolutely sure oven pilot light has been relighted as soon as range shut-off valve is turned on. On 27-, 29- and 31-foot International models, the oven gas shut-off valve is the left-hand knob on the face of the oven. It should be turned off when traveling, or when gas tanks are being changed. You need not turn on the shut-off valve and relight the pilot unless you want to use the oven. The shut-off for the top burners is located under the range top and also should be turned off while traveling.

RANGE EXHAUST HOOD.

The range exhaust hood provides venting of cooking heat and smoke from the trailer. The vent is opened by flipping open the filter cover on the under-surface of the hood. The optional fan (standard in International) is turned on by pressing the push button switch next to the filter cover. The filter should be cleaned periodically with warm water and dish soap. It can be removed for cleaning by sliding it up inside the roof locker. The inside of the vent housing

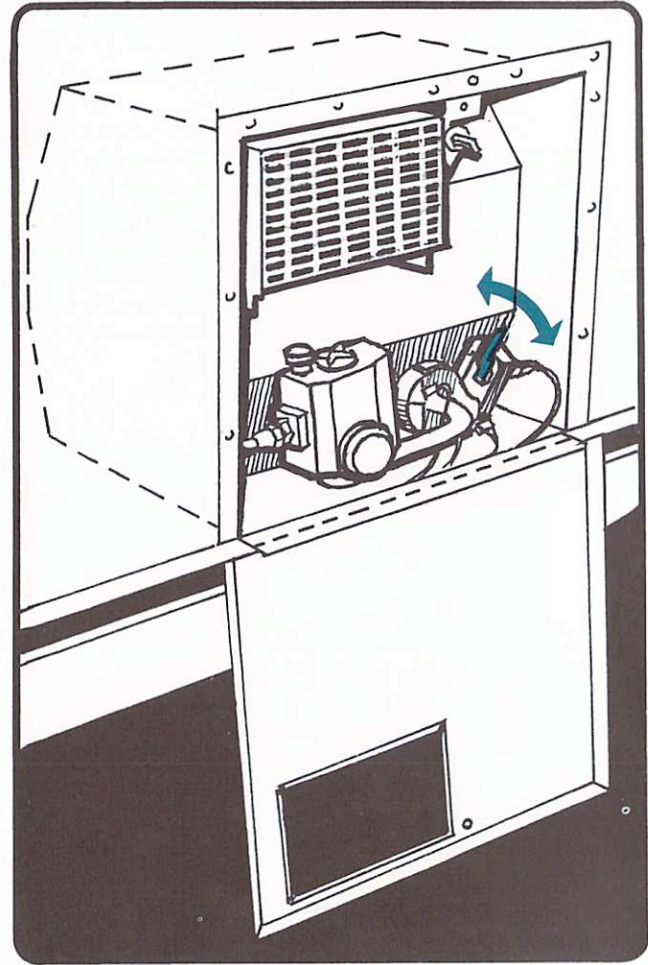

should also be kept free of grease and dirt accumulation by periodic washing.

THE WATER HEATER.

Your Airstream is equipped with a Bowen gas water heater which is built to give you long years of trouble-free performance. It is equipped with a Robertshaw control that has a 100% shut-off safety valve which shuts off the gas supply in the event of pilot flame being extinguished or if excessive water temperature occurs. It is lighted and serviced from outside through an access panel at the left rear of the trailer.

PROCEDURE FOR LIGHTING OR RELIGHTING:

1. Be sure the heater is filled with water. Open hot water faucet at sink — when water flows, heater is full.
2. Turn gas cock knob to OFF position and temperature indicator to lowest temperature position.
3. Wait sufficient length of time to allow gas, which may have accumulated in burner compartment, to escape (approximately 5 minutes).
4. Turn gas cock knob to pilot.
5. Depress knob and actuate lever of spark igniter back and forth between its stops until the pilot flame ignites — this may require several movements of the lever.
6. Keep knob depressed for 1 minute after pilot flame ignites.
7. Turn the gas cock knob to ON.
8. Set the lever indicator for the desired water temperature.
9. To shut down the heater, turn gas cock to OFF position.

PILOT FLAME ADJUSTMENT.

If the pilot flame does not have a small orange tip, the pilot is not getting enough gas. The flame should be about $\frac{1}{4}$

inch in vertical height when the water in the tank is cold and the burner is off, $\frac{1}{4}$ to $\frac{3}{8}$ inch in horizontal length when the tank is warm.

A large orange flame indicates excessive gas supply, which will result in short pilot life and early replacement. The pilot has been properly adjusted at the factory and should operate with a blue, orange tipped flame enveloping the pilot thermocouple. Removal of the pilot adjustment cap in lower right corner of control will reveal the pilot adjustment screw. Turning this screw clockwise reduces the flow of gas to the pilot (blue flame) and counterclockwise the gas supply is increased (orange flame). Always replace the "pilot adjustment cap" to prevent gas leakage.

AIR SHUTTER ADJUSTMENT.

All fuels depend upon air (oxygen) to give them proper burning characteristics. A yellow, smoking flame indicates a lack of air and a noisy hard blue flame indicates a lack of air. The air shutter slides back and forth along the burner tube and is held in place by a small shutter adjustment screw. Loosen the screw for adjustment. A good method of adjusting the air shutter is to slide the shutter to the right until yellow tipping occurs on the main burner flame (not pilot) and then slowly slide the shutter to the left, until all signs of yellow tipping are gone. When proper adjustment has been obtained, tighten screw holding the air shutter.

AIR CONDITIONER (OPTIONAL). TO PLACE UNIT IN OPERATION.

1. Close doors, windows and ventilators.
2. Set thermostat to desired temperature. 75° is a normal setting. Do not make frequent setting changes.
3. Push fan switch (located under thermostat on left side)

water heater
air conditioner

APPLIANCES



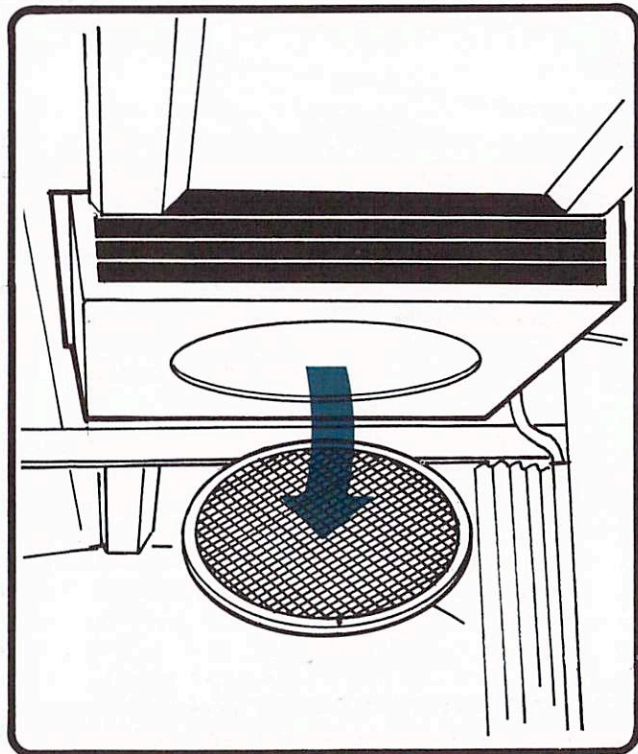

to HI position.

4. Push main switch (located under thermostat on right side) to "cool."

NOTE: After the inside temperature has reached thermostat setting and the outside temperature is 90° or less and is expected to stay so for a period of time, unit may be operated on LO speed.

TO OPERATE UNIT AT LOW SPEED.

Push fan switch to LO position. This may be done while unit is running on HI speed.

If unit cannot maintain thermostat setting, push fan switch to HI.

TO SHUT DOWN UNIT.

Push main switch to OFF position.

CLEANING OF FILTER.

SHUT DOWN UNIT BEFORE REMOVING OR REPLACING FILTER.

Remove filter by taking out screw. Brush off loose lint. Run water through filter or slosh it up and down in a pan of mild detergent or soapy water. Rinse thoroughly. Shake out excess water and wave through the air to dry. Replace filter. Lock in place with screw.

The Air Conditioner comes equipped with a low voltage starter kit. This will permit you to start the Air Conditioner at current as low as 90 volts.

For additional information see Air Conditioner Service Manual.

TOILET EXHAUST FAN

The toilet exhaust fan is located in the ceiling of the bathroom, to operate push switch on.

CAUTION: The fan is very quiet and easy to forget. Make it a habit to check to make sure fan is off after using to avoid running battery down.

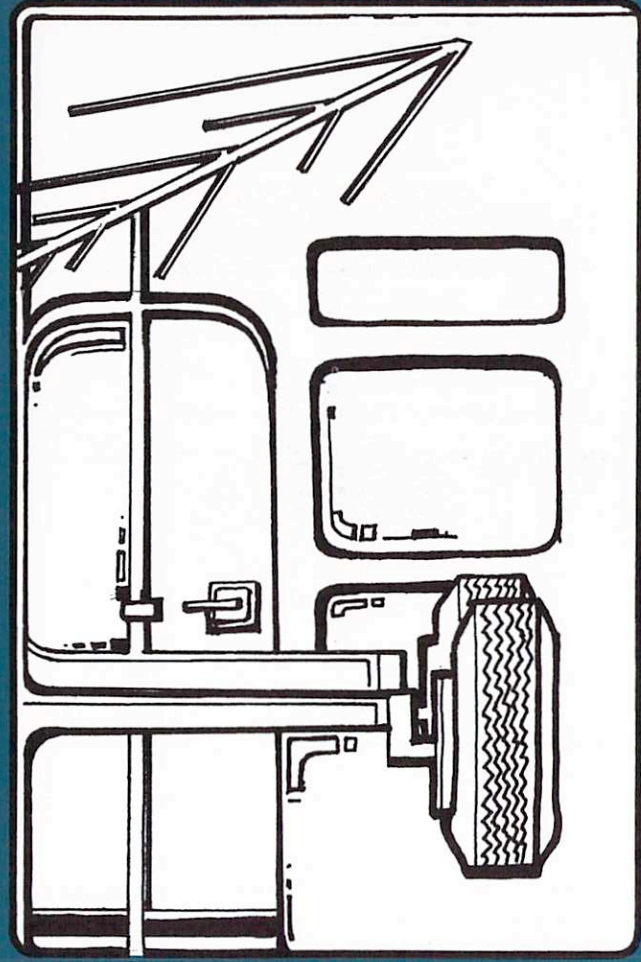

11

RUNNING GEAR & HARDWARE

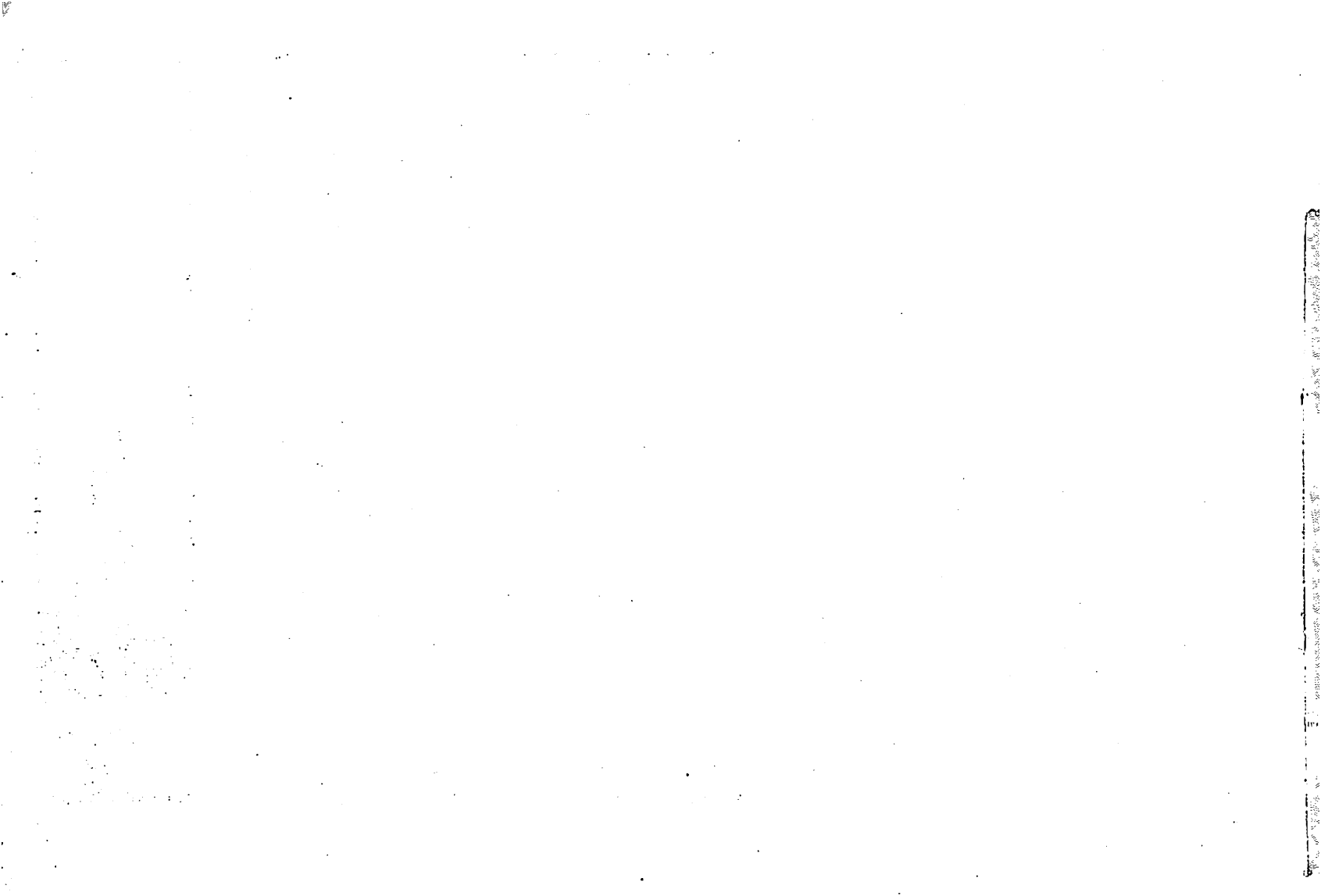

THE DURA-TORQUE AXLE.

The new improved Dura-Torque axle in your Airstream has been referred to by experienced trailerites as "the greatest thing that has happened to trailers since they invented the wheel." The axle gives a much finer ride than the conventional axle and spring, and by elimination of the great number of parts, eliminates sources of maintenance problems. The Dura-Torque is designed to last the life of your trailer without service except to the wheel bearings.

WARNING!

Under no circumstances should any welding be done on or near the Dura-Torque axle (such as in mounting skids or welding in the area of the axle where the heat may be transferred to the axle). The heat generated by welding will destroy the rubber pads and cause failure of the axle.

THE KELSEY HAYES ELECTRIC BRAKES.

The Kelsey Hayes 2-shoe adjustable brakes on your Airstream are the finest electric brakes available on the market. They are operated by the 12-volt current from your car and should be hooked-up so that you have an integral system with your car brake.

Do not use the break-away switch as a parking brake since it will burn out the brake magnet and discharge the trailer if left for a sustained period.

The number one cause of trouble with trailer brakes is improper installation of the controls in the tow car. To prevent problems and insure satisfactory braking action it is necessary that you install a Kelsey Hayes controller and a variable resistor in line with the brake controller in your car. Do not attempt to use any other brand.

To adjust your Kelsey Hayes brakes is quite simple. Follow this procedure:

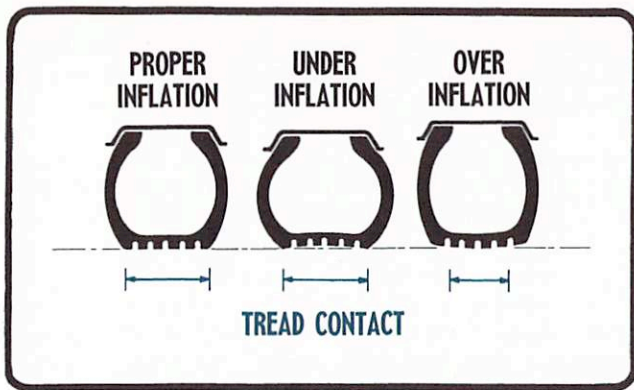

1. Remove the small rubber plug at the base of the backing plate on the brake drum.
2. Jack the wheel up so you can spin it by hand; tighten the brakes (using a brake adjusting tool or a screwdriver that has been bent to a 90 degree angle) until the wheel is locked; then back off until you have a free spinning wheel (which will be approximately 15 notches).
3. Repeat this operation with all of the other wheels on your trailer.

Neither Kelsey Hayes Co., nor Airstream Inc. will assume any responsibility for the brakes on your Airstream if the tow car is equipped with any other brake controller or any other variable resistor than the Kelsey Hayes,

THE TIRES.

Your Airstream is equipped at the factory with name brand travel trailer tires. Your Airstream dealer cannot make adjustments on these tires — they can be made by any dealer that handles that particular brand. When you

axle
brakes
tires

RUNNING GEAR &
HARDWARE

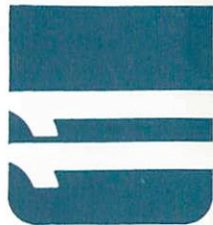

are on the road, if you have any problems with your tires, check in the classified pages of the telephone directory for the nearest dealer. The following rules will help you get top performance and maximum life from your tires.

1. Always check air pressure in your tires before starting on a trip. Tires should be cool when checked. Be sure you maintain correct pressure when cool, but never "bleed" air out after you have been driving or when tires are hot. The tires are designed to compensate for the higher pressure that will be encountered as they are driven; "bleeding" air out could result in under-inflation when they have cooled. The proper pressure for tires for tandem axle Airstreams (7:00 x 15, 6 ply) is 45 psi; for single axle Airstreams (7:00 x 15, 8 ply) is 60 psi. Make sure valve cores and valve caps are tight to prevent loss of air.

NOTE: On single axle Airstreams the 65 psi will cause a harder ride, lower pressure may be used if you do not load your trailer too heavily. Refer to figure on page 101 if in doubt.

2. When parked between trips, maintain recommended air pressure in all tires at all times.
3. Whenever possible, park in shaded areas so that tires are not exposed to the direct rays of the sun.
4. If parking for extended periods of time, put your trailer on blocks so that tires do not touch the ground. If you park in areas where sunshine prevails such as the desert region, California, or Florida, it is recommended the tires be covered to protect them from the ozone deterioration of the sun. A handy cover, which is easily attached and removed, is available through Wally Byam Stores. If local parking regulations permit, and facilities are

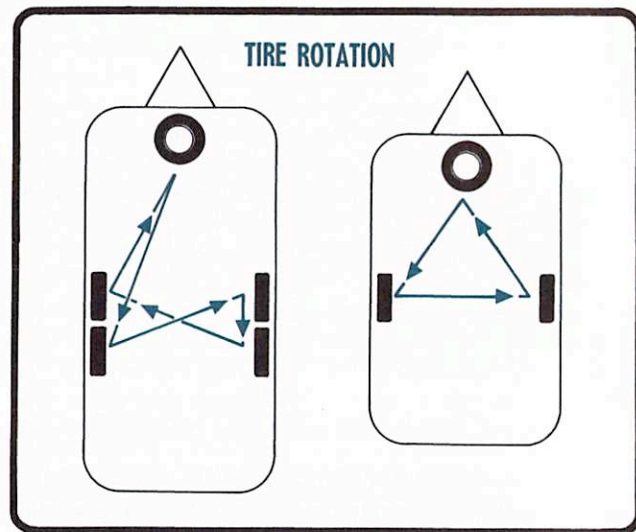

available, remove tires and store them in a cool dry enclosure.

CHANGING FLAT TIRES.

One of the bonuses that result from having independent Dura-Torque suspension on tandem model Airstreams is the ease with which a flat tire may be changed. On a tandem trailer, to change one of the wheels it is necessary only to drive the remaining wheel on the same side up on a block about 6 inches thickness. The wheel with the flat tire will then clear the ground to a point where it is possible to remove it and replace it without the use of a jack. If a spare is not carried, it is quite possible to drive the unit for some distance on 3 wheels only. On single axle trailers, it will be necessary to jack up trailer to change tires. Place the jack

under the main frame rail. A 3-inch aluminum pad is provided to indicate the proper position for the jack.

FOLD-AWAY STEP.

The Airstream fold-away step can be lowered into the open position by pulling out the handle that is located between the main door and the step. The step should drop fully out into a locked position. In case the step does not lock, be sure to pull out on the step itself until it does drop into the locked position. To return step to the folded-up position, grasp the lower front edge of the step (keep fingers off top of step!) and push the step upward into the opening with enough force to engage the lock which is integral with the handle.

The auxiliary step extension (optional) can be placed into position by unfolding the wings of the step extension and inserting the square bars into the holes provided in the front of the fold-away step. Do not travel with auxiliary step inserted in fold-away step. Place the auxiliary step in the storage bracket provided under the trailer, forward of the main step.

THE MAIN DOOR.

It is very important that the main door of your trailer be completely closed and locked during towing. If it is not properly secured, the constant vibration of travel can cause it to fly open and possibly cause damage.

CAUTION: The door latch acts as a deadbolt when it is locked. DO NOT slam the door with the door latch in the locked position. Should you find it rather difficult to unlock the door, push in to release the pressure on the door latch.

SCREEN DOOR.

The screen door is designed to provide the maximum amount of ventilation and convenience while at the same time be out of the way and unnoticeable when not being used. To accomplish this the screen door is hinged at the same point as the main door so that when not needed, the screen door is latched to and practically becomes part of the main door. To use the screen door, unlatch it from the main door, latch the main door fully open with the latch provided on the side of the trailer, and close the center panel of the screen door. To take the screen door out of operation, reverse the process. Open the center panel to provide clearance for the door handle and latch the doors together.

The curved and flat windows in your trailer are of tempered safety plate glass — the same type of glass used for the side and rear windows of automobiles. The tempering process makes the glass incredibly strong, and at the same time prevents it from injuring anyone if it should be broken. It can be shattered by a hard blow, but if this should happen, the glass tends to shatter into small, dull, harmless particles. No special care is required for the windows, and they may be cleaned with any good glass cleaner. The front window gravel guard is made of long lasting Butyrate. This material can be damaged by harsh abrasive cleaners and should be cleaned only with soap and water.

OPERATING INSTRUCTIONS

You will notice that all opening windows open outward (Front corner windows do not open). To open: Unlock the latches on the lower window frame (see illustration), then

foldaway step
doors
windows

**RUNNING GEAR &
HARDWARE**



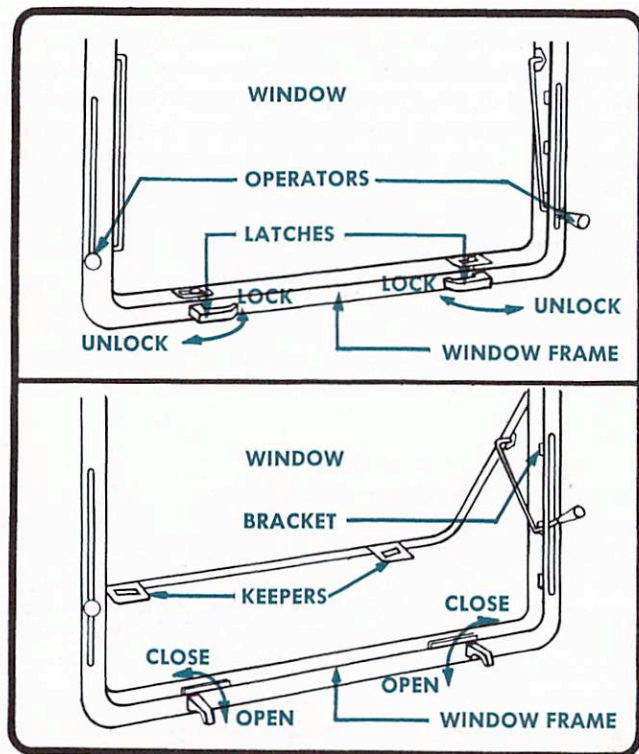

open the latches by turning them towards each other until the latches disengage from keepers.

Lift up and push outward slightly on the operators (on sides of window frame) until window is at desired position. Pull operators toward you and lower operators into one of the three sets of brackets provided in sides of window frames.

To close: Lift up and push outward slightly on operators to disengage them from brackets—lower window to close position. Close latches by turning them away from each other until they fully engage keepers on lower edge of window. Lock latches (see illustration), this will seal window

For maintenance and window replacement instructions see chapter 14.

SCREENS.

The door and window screens are made of plastic for longer wear and ease of maintenance. They can be easily cleaned with a damp cloth, and of course, they cannot rust. However, while the screen material will not burn, contact with fire, such as a lighted cigarette, will cause it to melt at the point of such contact. Should your screens become damaged for any reason, your Factory Service Center is equipped to replace the screen material.

CEILING VENTS.

The ceiling vents provide maximum ventilation and cooling in the trailer while still keeping the rain out. The vent lids are opened by rotating the hand cranks located on the frame. For maximum ventilation, both the front and rear of the vent should be opened. Lesser venting can be had by opening only one end. Opening one end can also be an advantage in case the wind is blowing hard from one end of the trailer, causing drafts. The optional fans increase the amount of ventilation gained. The screens can be removed for periodic cleaning by removing the hand cranks and merely pulling the screen downward to unhook the spring clips.

DOOR CATCHES.

Wardrobe and cabinet doors are equipped with hidden catches. To open, just squeeze the catch; to close, just

shut the door firmly — the catch will engage by itself. Doors under the beds and lounges are opened by lifting upward on the lower edge of the door, raise to the horizontal position and slide door back into bed frame.

DRAWERS AND SHELVES.

All drawers and shelves in “flexible storage” areas are removable, allowing you greater flexibility in arranging the storage of your possessions to your own particular liking. All drawers have molded-in handles for ease of operation. The drawers are built so they can be stacked and carried easily into the house prior to loading the trailer.

MEDICINE CHEST

This area is behind the mirror in the bathroom. The 120V and optional 12V outlets are located within the compartment so shaver and electric tooth brush may be left plugged in while mirror is closed. The small shelf beneath the main shelf will hold small medicine bottles and other small items.

CREDENZA TABLE (standard except models with Safari Twin Front Lounges).

The credenza table can be in either the open or stored position for towing. To open the table for use, slide it

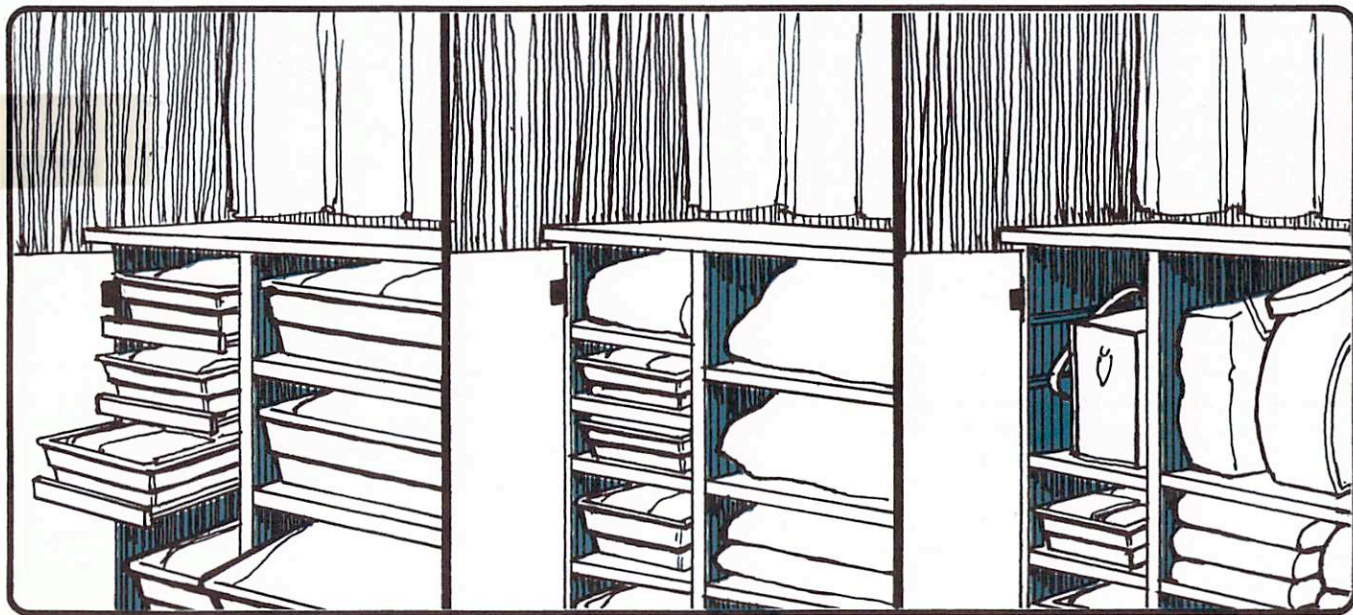

drawers and shelves
tables

RUNNING GEAR &
HARDWARE

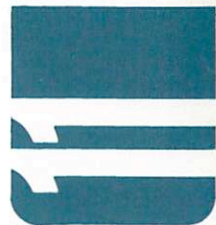

toward the rear enough to clear the front lounge and raise the table to the horizontal position. While holding it horizontally, unlock the folding leg and pivot the leg into the vertical position. The leg is unlocked by sliding the locking collar down the leg about $\frac{1}{4}$ inch. When the leg is moved into either position, it will lock itself.

To extend the table, unlock the latch under the table near the leg so that the extension slide can be pulled out. Lift up slightly on the table so that the leg is off the floor and pull the table frame (including the leg) out as far as it will go. Release the small catch on the edge of the table near the shelf and rotate the extension leaf over and lay it down on the extended table frame. The entire table can be moved fore and aft for maximum seating comfort by raising the leg off the floor and sliding the table along the supporting shelf. **NOTE:** When lowering the table into the stored position, be sure to secure the lock under the table which prevents the table frame from dropping downward. Also fasten the small catch on the edge of the table which prevents the top table leaf from falling outward.

FRONT TABLE (trailers with Safari Twin Front Lounges).

For extending see instructions above in "Credenza Table." Be sure table is in the lowered (horizontal) position while traveling. A latch is provided to hold this table in the upright position, out of the way for sleeping.

CONVERTIBLE LOUNGES/BEDS.

Those convertible beds which might be used for seating have a mechanism which slopes the seat for more comfort. The same mechanism locks the seat in the lounge position. To convert the lounge into a bed . . . pull back cushion down toward you, onto the seat. Grasp the front rail of the seat, lift approximately $\frac{1}{2}$ " and pull out seat to full exten-

tion (there are built-in stops). Now fold rear cushion back down to form the bed. To convert the bed back into lounge, simply reverse the process.

On side-pullout (gaucho) beds, the shelf behind the rear bolster is hinged to provide more sleeping space. When converting the bed into lounge, be sure to raise this shelf onto the blocks on the back side of the rear bolster. **NOTE:** On the front travel lounges and side-pullout (gaucho) beds, the space behind the rear cushion (below the shelf) is ideal for storing bedding.

MAKING BEDS.

The following technique will enable you to make and foldup the convertible lounges/beds quickly. Make the bed in a normal manner, pulling the bedding tight (we recommend bottom fitted sheets — $\frac{3}{4}$ bed size).

1. Remove and store pillows.
2. Fold in the ends of bedding neatly to expose approximately 2 inches of the mattress.
3. Starting from edge closest to you, roll up the bedding (as tight as possible) toward back wall, until entire bedroll is under the shelf.

This will enable you to convert bed into a lounge without disturbing the bedroll. To make up the bed, pull out the lounge as described earlier, roll out the bedding and tuck it in.

The fixed twin bed will pull out enough to facilitate the tucking in of the bedding along the back wall.

DRAPES.

All drapes in your Airstream are equipped with a track and sliders on both top and bottom. This keeps the drapes close to the window and wall. When the drapes are closed they block vision and light very well. The double track and slider

system also keeps the drapes neat looking at all times, and prevents the drapes from swinging while traveling.

TELEPHONE SHOWER HEAD.

The telephone shower head is designed to give maximum flexibility in usage and provide for water saving techniques when using your trailer on self-containment. To conserve water the shower should be held in hand and moved about the body. Normally, the best water conservation procedure is to wet entire body and then turn water off. Apply soap, lather thoroughly, turn water on and rinse soap off body. Some people find sitting in the tub a little more convenient than standing while using this method.

On International models, the shower can be turned on and off without disturbing the hot-cold adjustment, because this feature is built into the faucet. In the Land Yacht series, a small valve is provided on the shower head for this purpose. As a fixed shower, the head can be attached to either of the two wall brackets, however, more water is used this way.

The telephone shower is also used to fill the tub for taking a tub bath. The shower head should be attached to the lower wall bracket and directed into the tub for this purpose.

The dump valve handle has a wire loop which locks the handle in the closed position. This lock should always be used while traveling to prevent the valve from working its way open.

To unlock the valve handle, push outward on this wire loop and it will snap loose and allow the valve to be opened. Before attempting to lock handle in place with this wire loop, be sure handle is pushed completely into a closed position.

OPERATING INSTRUCTIONS:

Opening closing and rotating of T.V. antenna is accomplished from **inside** the trailer. The controls are on the ceiling of your trailer directly below the antenna. To open antenna dipoles swing arm (see illustrations) (1) to opposite position. **Hold arm** in this position (2) and slide lock completely **into** side of arm. (3) Turn on T.V. set and select channel. While watching T.V. picture, rotate large round knob on antenna control panel counter-clockwise until best picture is obtained. The antenna and controlling knob have a built-in stop after antenna has rotated 360°, so if antenna stops, reverse direction of rotation to adjust for best picture quality. Whenever changing T.V. channels, re-adjust antenna direction for best picture quality.

TRAVEL POSITION:

To close T.V. antenna and place it into travel position do the following two things (at antenna control panel).

1. Rotate knob clockwise until it stops (this places antenna in the proper direction for travel).
2. Hold arm in its locked position. At the same time slide lock completely **out** (2) of side of arm. Now **slowly** swing arm to opposite position (this closes dipoles).

NOTE: Before pulling away, glance at T.V. antenna to see that the dipoles are closed and that the antenna is pointed straight forward.



shower head
dump valve lock
t.v. antenna

RUNNING GEAR &
HARDWARE

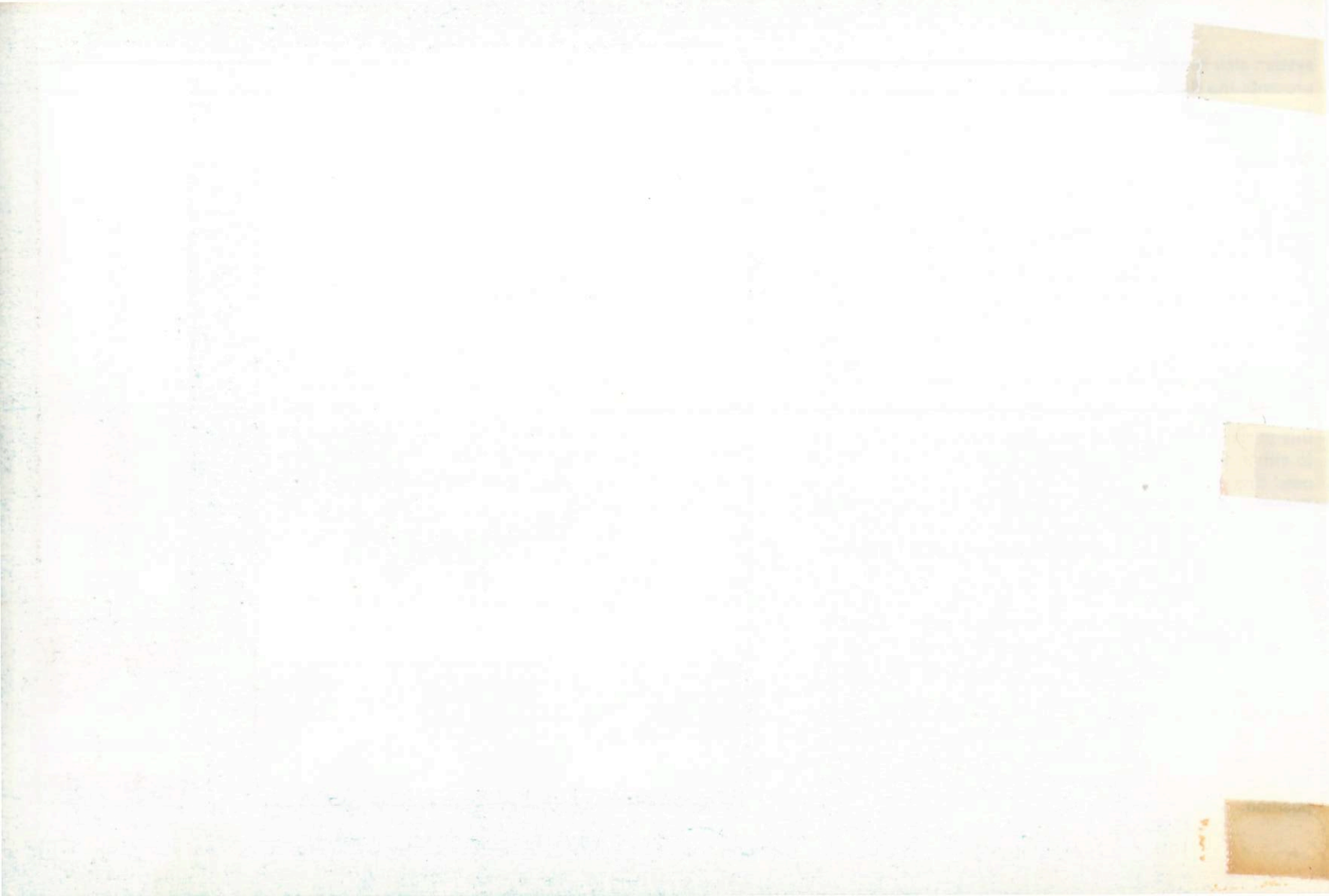

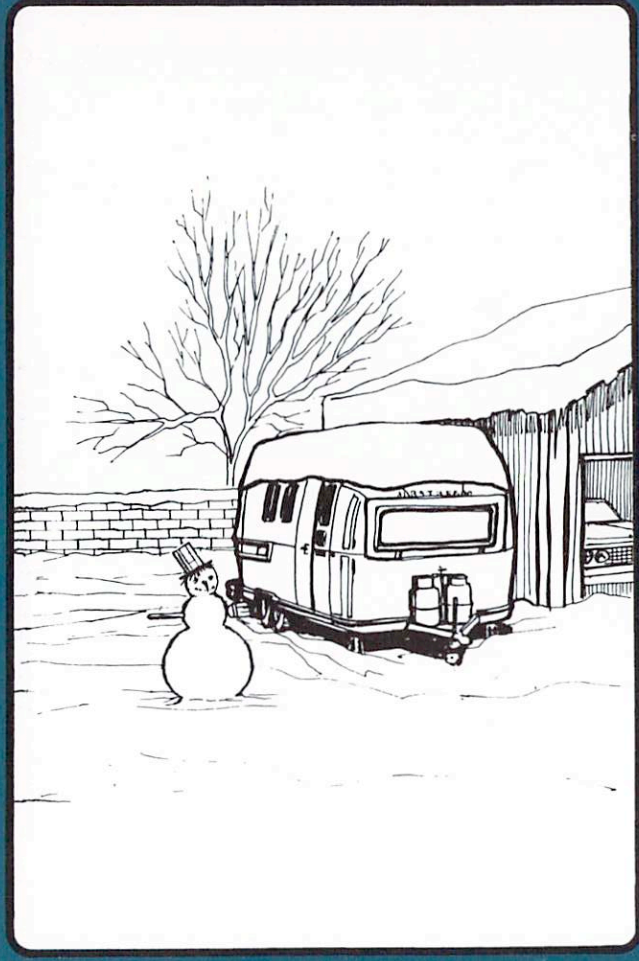

TRAILER STORAGE - WINTERIZING

12

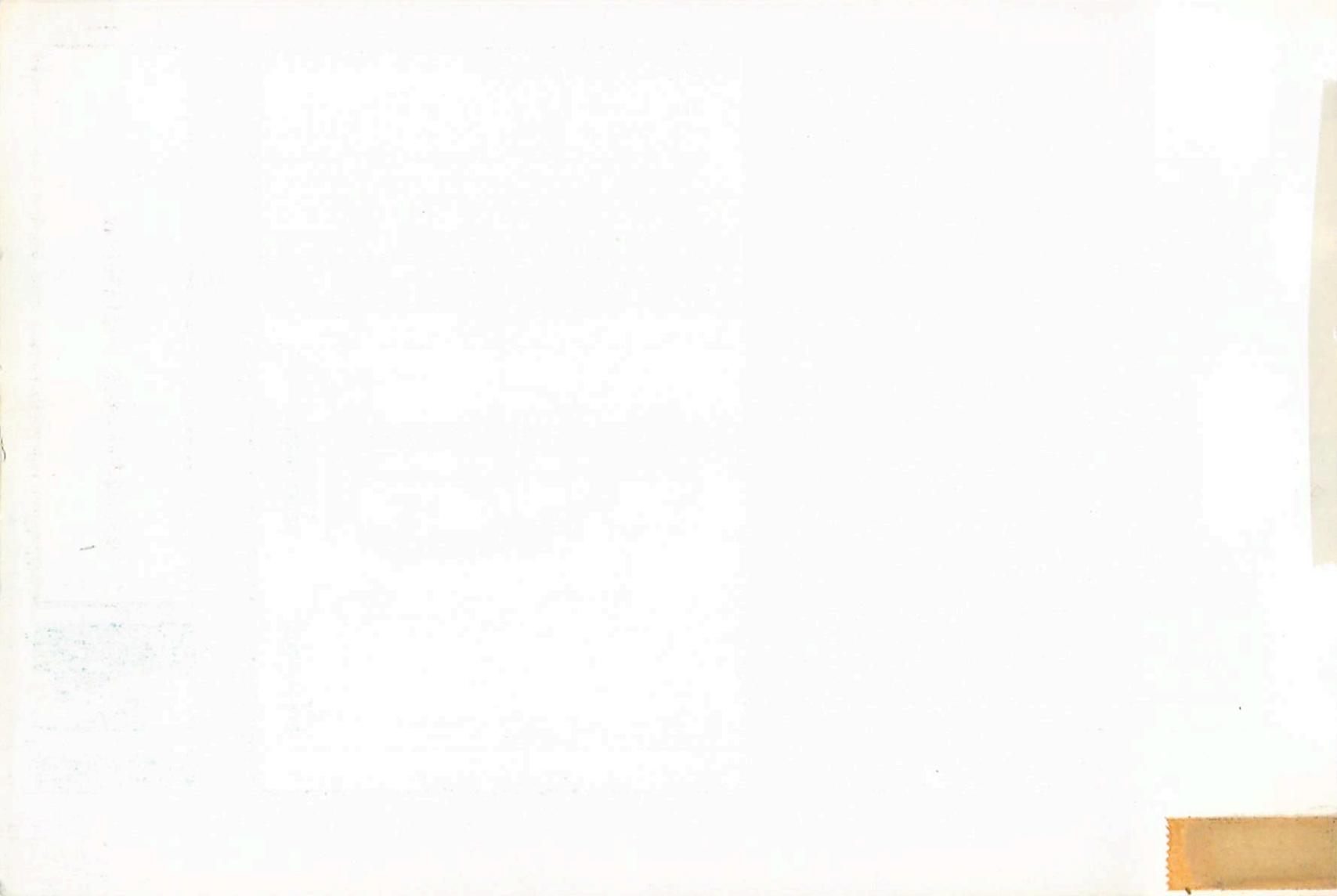

TRAILER STORAGE.

When storing trailer for short or long periods during above freezing weather — use the same precautions as you would in your own home in regards to perishables, ventilation and rain protection. In addition, for prolonged storage periods, flush out all the drain lines and the holding tank. Also, drain the water system to prevent water from becoming stale. (Including the water heater and the water storage tank.) For draining water system, use applicable instructions in the next section on winterizing your Airstream.

WINTERIZING YOUR AIRSTREAM.

The main consideration in winterizing is to guard against freezing damage to the hot and cold water systems, the waste drain system (including the traps), the waste-holding tank, the water heater and the battery. To completely winterize your Airstream, follow this procedure:

1. Level the trailer from side to side and front to rear. Open all the faucets.
2. Turn the water pump switch to the OFF position.
3. Open all drain valves. There are three: Two are located in the One-Stop Service Center and one is at the water storage tank in the front of the trailer.
4. While the water is draining from the system, open and close the toilet flushing valve. Depress hand spray thumb button and hold the spray head below rim of toilet to drain the hand spray line. There is great danger of damage from freezing if water remains in these lines and valves.
5. Lower the front of the trailer as far as the jack will allow and see if the water will continue to drain. Then

crank the jack up as high as it will go and let any remaining water drain out.

6. After the water has stopped running from the drain lines, apply air pressure to the drain lines with all drain valves and faucets still open. This will force any remaining water from the water heater and any water which may be trapped in low areas.
7. Pour about a cup of antifreeze (glycol) into the lavatory, sink and tub drains to prevent freezing of water in the traps.
8. Be sure to open the waste-holding tank drain valve

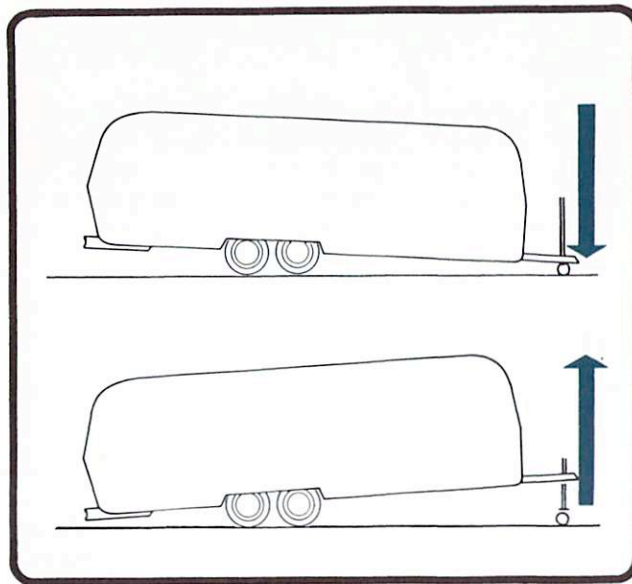

and drain and flush the tank thoroughly. (This is very important as the sewage in the tank, if frozen, could seriously damage the tank.)

9. Remove the lower portion of the water purifier, if your trailer is so equipped, and drain the purifier.
10. Disconnect the inlet and outlet connections of the water pump and turn the pump by hand until all water is expelled.
11. It is very important for optimum life of your battery to check it periodically and to keep it fully charged. This is especially true in winter months when the temperature may drop below freezing. The following points are important to consider to get the most out of your battery.

- a. A fully charged battery will not freeze under any normal circumstances, therefore, it is imperative that you keep your battery charged during the winter. A safe level of charge is a specific gravity reading of 1.225. A fully charged battery has a specific gravity of 1.250 to 1.280.

- b. A normal battery will discharge by itself in 30 to 45 days, therefore, it is necessary to periodically check the battery and charge it as necessary. We suggest checking the battery at least every 2 weeks in freezing weather. This is important because if you allow the battery to be completely discharged too many times, it will shorten its life considerably.

- c. When charging your battery, we recommend using the built-in charger in your univolt system because it automatically controls the charging rate and the level

of charge. If you remove your battery and have it charged by a service station, do not let them give it a "quick charge" since this can drastically shorten the life of your battery. (This also applies to your car battery.)

- d. If your trailer is equipped with a battery checking device, you can tell the approximate condition of your battery with it. However, if the trailer is plugged into 110-volt power, be sure that you either unplug the trailer or turn off all the circuit breakers before reading the battery checking device. Reading the battery checking device with the trailer plugged in will give a false indication of battery condition because of the built-in univolt charger.

12. Remove any items (food, cosmetics, etc.) from trailer interior that might be damaged by freezing — or might do damage to trailer by breaking their containers while freezing.

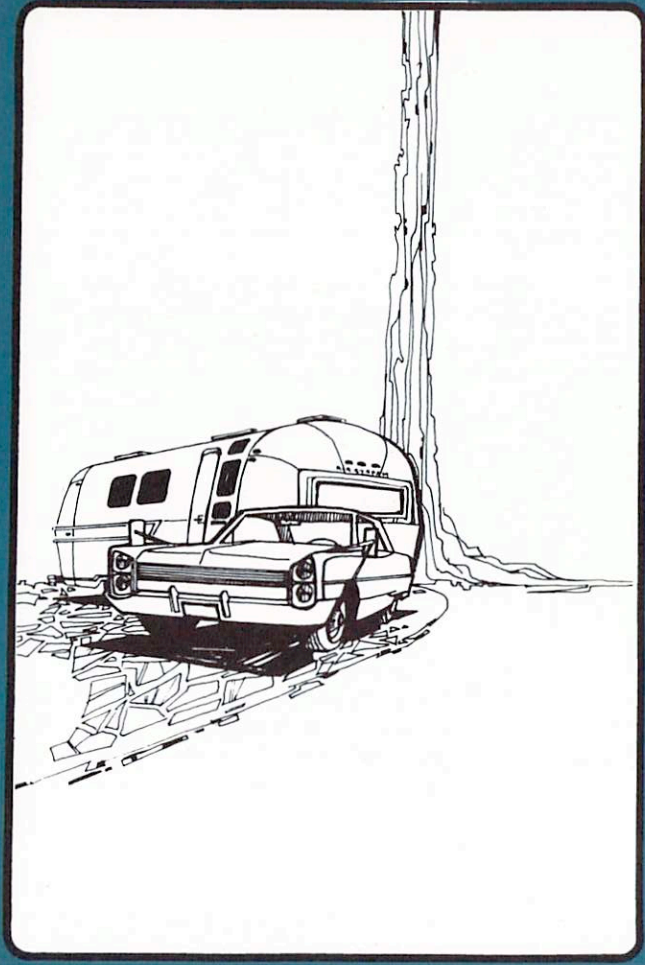

13

EQUIPPING TOW CAR



YOUR CAR.

Since your Airstream is designed and built for easy towing, almost any car has enough power and weight to tow it under level, dry conditions. However, experience has proven that a heavier car is advisable for towing the larger units (27-foot and up) under difficult weather conditions and on hills. A heavier car will also help you maintain complete control on slippery downgrades.

WEIGHT-TO-HORSEPOWER RATIO.

From the experience of thousands of trailer travelers, Airstream engineers have developed a "weight-to-horsepower" ratio to serve as a guide for matching tow cars to Airstreams. To obtain this ratio, add the weight of the trailer to the advertised weight of the automobile and divide by the advertised horsepower of the automobile.

Example: To determine the weight-to-horsepower ratio for a 250 horsepower Ford sedan weighing 3829 pounds and a 27 foot Airstream weighing 3950 pounds, the formula would read:

$$\frac{3950 + 3829}{250} = 31.12 \text{ pounds per horsepower}$$

Experience has shown that the practical upper limit for most road conditions is 60 pounds per horsepower. Anything in the range of 30-40 pounds per horsepower is very adequately powered, with any lower ratio being a "hot rod."

Another guide for matching the tow car to your Airstream is to have the car and trailer weights nearly the same. Your Airstream will tow easier if it is not markedly heavier than the tow car. Of course, if your car is heavier than the Airstream so much the better.

The car transmission can be manual or automatic as you

prefer. Automatic transmissions are recommended by the automobile manufacturers because they do a better job of controlling engine loads than the average driver can with a manual shift. An automatic transmission will prolong your car's engine life.

THE HITCH.

We strongly recommend the use of a frame mounted, weight equalizing type hitch. We do not recommend the use of an axle hitch except for emergency use and then only for a minimum distance. The weight equalizing hitch, by use of the load bars, transmits the hitch weight of the trailer equally onto all four wheels of the automobile and at the same time transmits a portion of the load back onto the wheels of the trailer. The amount of load equalization provided by this hitch is adjusted by means of the amount of tension placed on the load leveling bars. When the hitch is properly installed and adjusted, the rear car and trailer hitch should be slightly high when **parked** on level pavement.

The illustration on page 30 shows the relationship between the tow car and the trailer with various hitch conditions. You will note that if the load leveling bars do not have enough tension on them, the nose of the trailer and the rear of the car will ride low. A "nose low" trailer does not tow as well as one which is riding level and at the same time a car which has most of the weight on the rear axle will be dangerous to steer because of the light load on the front wheels. If the load bars are pulled up too tight, then the nose of the trailer and the rear of the car are raised up above the level position. The biggest problem encountered with this type of hookup is that you lose much of the traction on the rear wheels of the car making acceleration

the hitch

EQUIPPING TOW CAR



difficult on loose gravel, snow or ice. Make certain the attaching points for the safety chain and the breakaway switch are on the portion of the hitch that is welded to the car, and not on the removable ball mount.

SWAY CONTROL.

Several types of sway control devices have been introduced in the last couple of years to help reduce the swaying tendency when towing trailers at high speeds. There are two basic types of sway control devices . . . cam type and friction type. Because both of these devices do a very good job of controlling trailer sway, we recommend either type. In order to properly align the cams on the cam-type sway control hitch, it is necessary to park the car and the trailer in a perfectly straight line on level pavement. With the car and trailer in a straight line, adjust the cam arms so that the mating portion of the cam on the load leveling bars and those on the trailing arms are in perfect alignment. Be certain this is done with the car and trailer absolutely straight. With the cams aligned as described, tighten the nuts on the "U" bolts securely so that the cams cannot move out of adjustment. Adjustment of the sway control device on the friction type hitch is not as critical as the cam type, however, it must be properly adjusted for optimum performance. The amount of sway control obtained from this device is controlled by adjusting the tension on the friction plates.

HITCH BALL HEIGHT.

By far the worst situation in hitch installation is if the hitch ball is installed too low on the car. If the hitch is welded on the car frame so that the ball is too low for the particular trailer, no amount of adjustment of the hitch or the linkage to the trailer will compensate for this error. We

have determined through the statistics from Caravanner Insurance that this is, by far, the most frequent cause of accidents. Proper hitch ball height is especially important when towing a tandem axle trailer, since a low hitch ball will lower the nose of the trailer thus throwing more of the weight on the front wheels of the trailer. This changes the center of support for the trailer and increases the tail-wagging tendencies.

The only correction which can be made in this situation is to have the hitch changed so that the ball is at proper height for the particular trailer. The recommended hitch ball height for the 1969 Airstream trailers is 19" for the 23-ft. through 31-ft. models. This height is measured from the ground to the top of the hitch ball, with the car parked on level pavement. To be absolutely certain of proper hitch height on your car, use the following method. Park the trailer on level pavement and get the trailer level with the ground by raising or lowering the front hitch post. With the trailer perfectly level measure the distance from the ground to the top of the ball socket in the trailer coupler. Then have the distance from the ground to the top of the hitch ball on your car made to this dimension plus an additional 1/2" to 1" for the car settling due to additional weight. In other words, if the distance from the ground to your trailer hitch socket is 19" then set the distance from the ground to the top of the hitch ball on your car at about 19 1/2" to 20". If your present hitch ball is too low for your particular trailer, it can be raised slightly by the use of a higher ball fitting. However, we do not recommend this for extended periods. Use this remedy only for a temporary time and then have your hitch modified for the correct height. Do not panic if your hitch ball is off up to 1", however, we would recommend having it raised at your earliest con-

venience. On tandem trailers, it is better to have the hitch ball a little too high, which will assure that your Airstream does not become tail heavy. If you find your hitch ball is over 1" too low, we strongly urge you to have it corrected at once.

THE ELECTRICAL CONNECTOR.

A seven-conductor auto cord wiring system is used to connect your Airstream to your car. Through a single, locking, polarized connector, your trailer battery will be charged, its brakes will be operated, and the running and signal lights will be activated simultaneously with those on your car. This cord is supplied with a connector at the point it exits from the trailer and therefor can be removed completely and stored when not in use.

When hitching up check both connectors. See wiring diagram in chapter 7.

BRAKE CONTROLLER.

Your Airstream is equipped with Kelsey Hayes two shoe adjustable brakes...the finest trailer brakes available. To insure proper operation, your car should be equipped with a genuine Kelsey Hayes controller and resistor. Your Airstream dealer will either make the installation, or supervise and road test it for you. If you have any other controller already on your car, have it removed, and have a Kelsey Hayes controller installed.

ACCESSORIES FOR YOUR CAR.

A truck or trailer type rear view mirror is required by law in most states. This is to allow you to see out past the trailer. Several good makes are available from your dealer. A right-side rear view mirror is also highly recommended.

If your car has an automatic transmission and you intend

to travel through mountainous country, you may wish to have a transmission oil radiator such as the Hayden Trans-Cooler installed to help your engine and transmission to run cooler and prevent possible damage. This is available through your Airstream dealer, and heartily recommended if you plan much driving in mountainous, or in hot climates, or if your car is air conditioned. If you plan to buy a new car and intend to keep it for several years we strongly recommend purchasing the trailer towing options offered by most car manufacturers. These options include such things as oversized generator, oversized radiator, heavy duty springs and shock absorbers, oversized fan and other items depending on the make of car.

electrical connector
brake controller
accessories

EQUIPPING TOW CAR



10
10

10
10

10
10

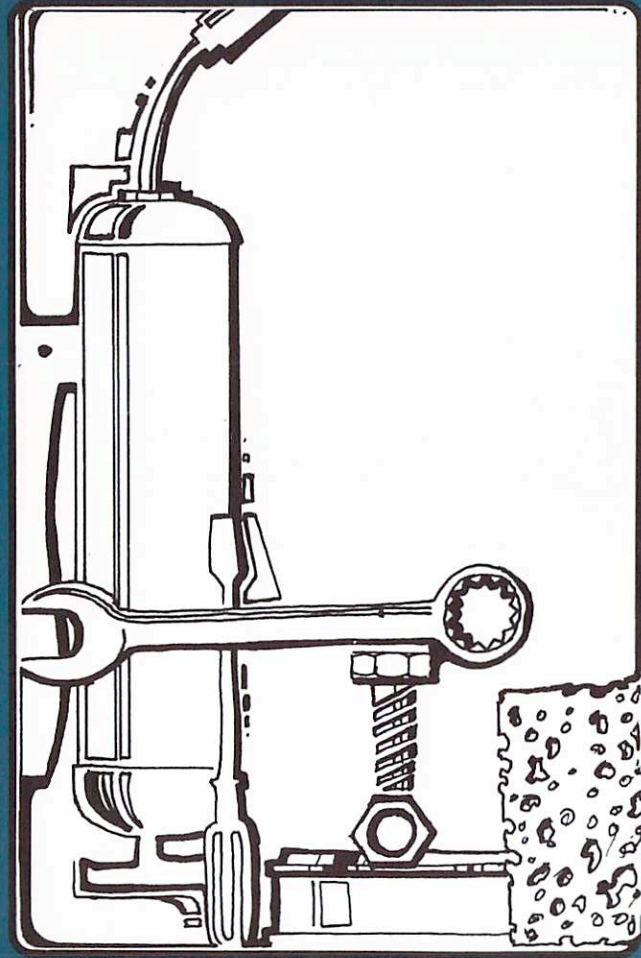

14

LUBRICATION & MAINTENANCE

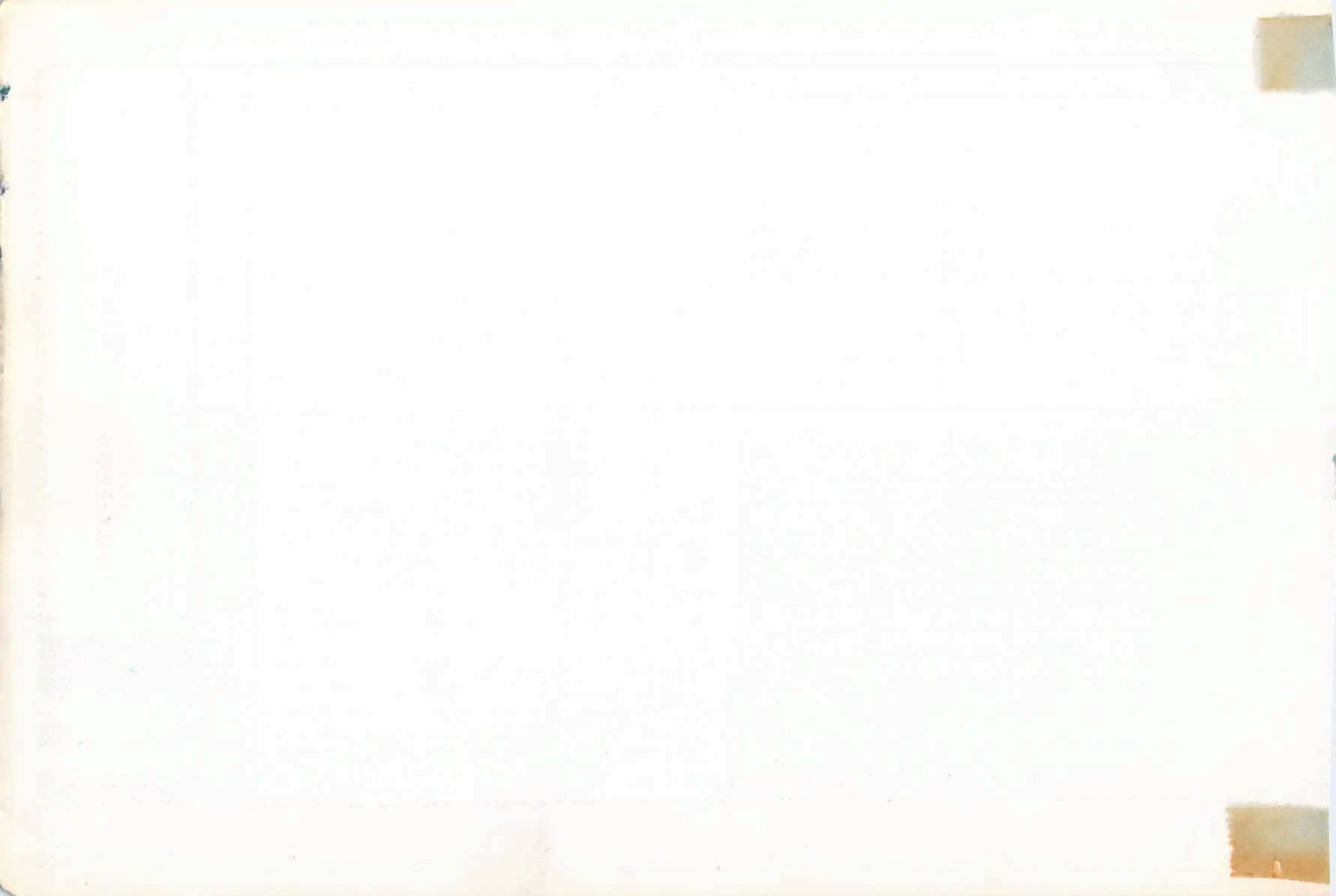

Your Airstream is without a doubt the finest engineered travel trailer ever to be mass-produced. Every design feature and component has been chosen with the thought in mind of giving you thousands of miles of trouble-free

operation. By adhering to the following minimum maintenance schedule and the additional exterior and interior maintenance suggestions you will enjoy all of the pleasure you dream of from your trailer . . . and more.

LUBRICATION & MAINTENANCE

ITEM	Every 1,000 miles or 30 days	Every 5,000 miles or 90 days	Every 10,000 miles or 6 months	PROCEDURE
Battery	X			Check water level — fill with distilled water only.
Smoke Hood	X			Clean fan blades and wash filter.
Hitch Ball Latch	X			Lubricate with engine motor oil.
Hitch Jack	X			Lubricate with light household oil (put oil can spout up under handle and allow oil to run down post).
7-way Plugs & Receptacle		X		Clean contacts and coat with "SPRA-KLEEN."
LPG Hold Down Knob	X			Lubricate with light household oil.
Entrance Door Hinge	X			Lubricate with light household oil.
Roof Vent Elevator Screws	X			Lubricate with light household oil.
All Exterior Door Locks	X			Lubricate by shooting in dry graphite.
Strike pocket on Main Door	X			Coat with paraffin.
Wheel Bearings			X	Clean, repack, and adjust.
Brakes			X	Inspect and adjust.
Tires	X			Check for foreign objects. Air pressure — page 102.
Tires		X		Cross-switch.
Water Pump		X		Check belt for wear and proper tension.
Wheel Lug Nuts		X*		Check for tightness.
Retracting Step		X		Lubricate moving parts.
Window Seals/Door Seals		X		Clean with mild detergent & coat with "Slipicone."

*NOTE: On new trailers check lug nuts every 200 miles for the first 1,000 miles.



SEASONAL CHECK-UPS.

Every fall and winter, and after any long storage, all of the gas appliances should be checked, cleaned and adjusted to insure safe and care-free operation. See the chapter on Appliances in this manual for maintenance procedures or have your Airstream dealer perform this "preventative maintenance" for you.

EXTERIOR MAINTENANCE.

ALUMINUM BODY.

Your Airstream has been protected by an acrylic lacquer finish applied at the factory. It will have on it an impervious film which should afford years of satisfactory service. As with any high quality finish, however, damage may occur if strong solvents or abrasive cleaners are used to remove road stains such as asphalt or insects. If the use of solvents is necessary to remove these materials, the areas affected should be wiped with a good grade lacquer thinner and touched up with a spray can of clear acrylic lacquer (available at Wally Byam Stores). If through the years the protective lacquer film is removed in extensive areas due to abrasion or highly corrosive atmosphere, a non-uniform appearance may result due to the differential oxidation of the underlying aluminum. Under these circumstances it is best to remove all lacquer with a good grade lacquer solvent and have your trailer re-coated or polish the entire trailer as described in the following paragraphs.

To keep your Airstream looking like new, it is important to keep the aluminum surface clean. Oils, greases, dust and dirt can be removed by washing with any mild non-abrasive soap or detergent such as those found around the house or

those recommended for washing automotive finishes. (Automatic dishwasher detergents generally are too strong and should not be used.) Under no circumstances should you attempt to use any of the acid etch cleaners that are available on the market as trailer cleaners. These are very dangerous for an amateur to use and, unless carefully handled, can be harmful to both the user and the trailer.

Cleaning solutions are best applied with a large sponge, soft cotton cloth or with a soft-to-medium bristle brush for stubborn spots. Cleaning should be followed by rinsing with clear water, taking care to rinse all detergents from cracks, grooves and crevices. Best results will be obtained by drying the surface with a chamois or soft cloth to prevent spotting or streaking. Always be careful to clean your Airstream in the shade or on a cloudy day and when the aluminum skin is cool.

After cleaning and drying, a good grade of non-abrasive automotive paste or liquid will greatly increase the life of the finish, maintain a uniform overall appearance, protect the finish from minor scratches and abrasions, and make later cleaning and maintenance easier.

Wax coatings should normally be applied every three to six months. They are best applied by hand but a soft, light-pressure mechanical buffer can be used if great caution is taken. Even non-abrasive waxes may cause surface marks if heavily buffed with high-pressure mechanical buffing equipment. The life of the wax coating is dependent on the degree and severity of exposure and maintenance between waxings. To get the longest life from wax coatings, excess grime and soil should be washed as often as needed with clean, cool water and the surface dried with a damp chamois or cloth. A protective wax coating is particularly important in coastal localities where the finish is exposed

to salt air, and in industrial areas where the finish is exposed to industrial waste fallout.

It is important to remove sap, seeds, gum, resin, etc., as soon as possible after they appear by washing and rewaxing. Sunlight and time will bake harden these materials so they may become ingrained into the actual finish of the aluminum, making them almost impossible to remove without heavy buffing.

If your trailer becomes exposed to unusually severe and corrosive atmospheric or service conditions, or has received improper or little maintenance, the acrylic coating may be destroyed and the aluminum may oxidize. This oxidation appears either visibly, as a white powder in very small granules, or can be felt as a roughness on the surface. To clean your Airstream after oxidation has taken place, the following procedure is recommended:

1. Wash your trailer with a good detergent using moderately hot water. Remove all dirt, mud and as much of the road asphalt as possible. If asphalt remains on the trailer after washing, use a small amount of kerosene on a rag and wipe the spots individually, being careful not to scratch the aluminum.
2. Remove all traces of acrylic coating with a good grade lacquer solvent.
3. Use a ready made aluminum cleaning preparation such as those designed for use on aircraft. One that has been found to be satisfactory is Met-All, available in Wally Byam Stores. Use a fairly large, soft cloth with some Met-All and rub lengthwise on the trailer or parallel with the grain of the aluminum (you will be able to determine the grain of the aluminum by looking closely at each panel). Do one complete sheet or section at a time.

4. Continue to rub the Met-All paste on the sheet after it has picked up a black color, which indicates that the coating of oxidated aluminum is being removed. Do not allow the rag to become caked or hard. Use either a clean rag or keep turning the rag as long as it is usable. When a cake of oxidized aluminum paste develops on your rag it is possible, with continued rubbing, to scratch the metal surface.
5. After completing the instructions under paragraph 4, use a soft, clean cloth that has been dusted with ordinary white wheat flour and buff off by hand the excess material that has been left on the sheet. (For extremely tough jobs, it may be necessary to do a complete job twice, except that the second time it is not necessary to wash the trailer with detergent.)
6. The use of a buffer is not recommended except in the hands of a thoroughly experienced person (if not expertly used, the buffer will leave a pattern on the aluminum surface).

Glass Wax (made by Johnson) has been found to be very useful in removing the last marks made in rubbing off the oxidized aluminum. After it is thoroughly clean, the entire surface should be re-waxed. Do not use Glass Wax if you plan to re-coat your Airstream with the clear acrylic lacquer.

CHASSIS AND HARDWARE.

The entire chassis has been painted with a high quality black chassis paint and the visible portions have been painted with an aluminum lacquer. To keep your trailer looking new it is recommended that the exposed portions of the chassis, bumper, gas bottles, etc., be repainted periodically with aluminum lacquer. These parts can be

check-ups
chassis & hardware

LUBRICATION &
MAINTENANCE



brush painted if desired but a more professional appearance can be had by using a spray can (available through Wally Byam Stores). It is also a good idea to repaint the vent covers for the galley exhaust fan, the refrigerator and the plumbing vents at the same time. If your trailer is equipped with air conditioning, the shroud over the air conditioner should also be painted.

Check the 7-way electrical connector for dirt and corrosion. Periodically, apply some "SPRA-KLEEN" to keep the contacts clean. When not using the trailer, it is a good idea to put a cover over the plug to keep out foreign matter.

WINDOW MAINTENANCE.

Window seals are of a material that will give good service with minimum care. Clean the seals with a damp cloth or mild detergent every 3 to 6 months. **DO NOT USE STRONG SOLVENTS** — they will damage the seals. A coat of natural silicone lubricant (slipicone) applied after the seals have dried will keep it flexible. Spread the lubricant evenly with a brush or finger working it in to the surface. The slipicone is available through Wally Byam Stores.

REPLACEMENT.

Should the window become broken, replacement can be ordered by part number. The number of each window is stamped on the sill, approximately 10 inches from the right hand side as seen from inside the trailer. The replacement window will have the edge trim and keepers already assembled.

To remove the window:

1. Open window about half-way.

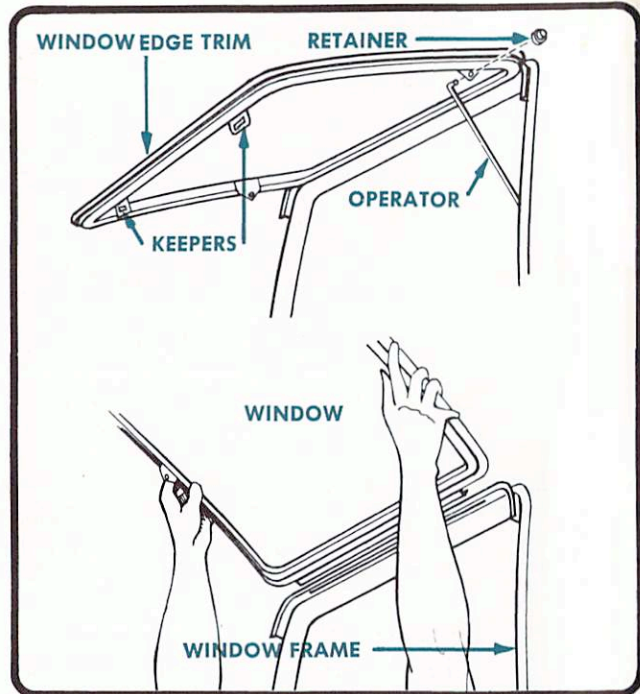

2. Remove the retainer from both operator arms (see illustration).
3. While holding window open, remove operator arm ends from holes in window edge trim.
4. Rotate window upward until hinge on window drops out of hinge portion attached to window frame.
5. Clean the seals and check for damage. Cuts in the seals may allow the window to leak; damaged seals should be replaced.

To install new window

1. Hold window in position as shown in illustration (be sure to rotate glass and frame upwards above the horizontal position) and insert hinge into window frame. Be sure window is centered in window frame. When hinge is properly located rotate window down about halfway closed. (CAUTION: Do not force window down — if the hinge is hooked properly, the window will swing down of its own weight).
2. Lubricate the rubber seals as described under "Window Maintenance."
3. Lubricate the hinge, using the same lubricant as used on the rubber.
4. Place outside ends of operators into holes in window edge trim and fasten retainers. Window replacement is now complete.

INTERIOR MAINTENANCE.

The interior of your Airstream is designed to be as trouble and maintenance-free as is possible. Following these tips will help maintain the interior of your Airstream sparkling new.

INTERIOR WALL FINISH.

The interior walls are finished in vinyl. Vinyl is best cleaned with a liberal application of suds from a mild household detergent such as Tide, with a small amount of bleach (Clorox, for example) added to the water. A damp bristle brush can be used for scrubbing to loosen and remove the soil. Then the surface should be rinsed with clear water and wiped dry.

NOTE: Use of kerosene, naphtha, carbon tetrachloride, lighter fluid, Energine, etc. should be avoided. They can cause damage to the vinyl. Abrasives should also be avoided, as they can wear off the print and unprotected

surfaces, and dull the lustre.

INTERIOR WOODWORK.

The interior wood in your trailer is lacquered for greatest durability and beauty. A cloth moistened with plain water is the best cleaning agent. DO NOT use alcohol or any petroleum-base solvents; they will attack the lacquer and mar the finish.

FLOORS.

Vinyl-asbestos floor tile should be cleaned with warm water and detergent, and coated with a good grade of clear wax such as Johnson's Paste or Vista wax. Self-polishing liquid waxes may be used, but they do not wear as well.

DRAPES AND UPHOLSTERY.

When storing your trailer it is a good idea to protect the upholstery from fading rays of the sun by putting aluminum foil between the window and the screen. The upholstery fabrics are treated with a moisture and stain repellent and therefore most dirt and stains can be easily removed with a damp cloth. If and when they become soiled, a good quality dry cleaning type upholstery cleaner can be used. The drapes are dry cleanable.

WORK SURFACES.

The work surfaces in your Airstream are of melamine laminate; they resist alcohol, fruit stains, scratches, acid, household alkali and heat up to 275°F. Waxing will help preserve the luster. Never use abrasive cleaners or use the surface for slicing or cutting. Protect from hot vessels.

LAVATORY AND TUB.

The lavatory bowl, counter top and tub in your Airstream bathroom are made of a special long-wearing, light weight, high strength material. When cleaning, use soap or detergent only — never use scouring powder. Wright's Silver

interior
window maintenance

LUBRICATION &
MAINTENANCE



Cream is an ideal cleaner for these parts.

CLEANING PROCEDURES FOR STAINLESS STEEL SINKS.

For routine cleaning of stainless steel sinks, ordinary soap or detergent and water will usually do the work. To prevent water spots and streaks, rinse sink thoroughly with warm water and wipe dry with a soft, clean cloth. Stubborn spots or stains that resist soap and water usually can be removed with a paste made of water and a mild abrasive cleaner such as Bon Ami or Ajax. When applying these abrasive cleaners, be sure to rub in the direction of the polish lines on the steel to preserve the original finish.

FINGERPRINTS.

Fingerprints are sometimes a problem on highly polished surfaces of stainless steel. They can be minimized by applying a cleaner which will leave a thin waxy film. An excellent cleaner for this purpose is the trade-marked product "Lac-O-Nu" (available through Wally Byam Stores). To use this cleaner, simply wipe on and remove excess cleaner with a soft dry cloth. After using, subsequent fingerprints will usually disappear when wiped with a soft dry cloth or with a cloth containing a little of the cleaner. If the surface is especially dirty to start with, wash first with soap or detergent and water.

SCALE AND HARD WATER FILMS.

Several types of films and scale can form on stainless steel from the use of hard water and strong detergents. They may be easy or difficult to remove, depending on the hardness of the water, type of detergent used, and length of time the film or scale has been permitted to build up. Regular cleaning at frequent intervals is the best prevention.

Heat sterilization can be done to stainless steel by filling sink with water at a temperature of 170 to 180°F. This will not injure the metal.

Certain foods and seasoning contain table salt, which in time will cause stainless steel to pit. These include ketchup, mustard and mayonnaise. Although stainless steel containers may be used for serving of such foods, where time of contact is relatively short, never use stainless steel containers for storing such foods. It is also advisable to wash deposits of these foods from stainless steel cutlery, pots and pans, before they stand too long.

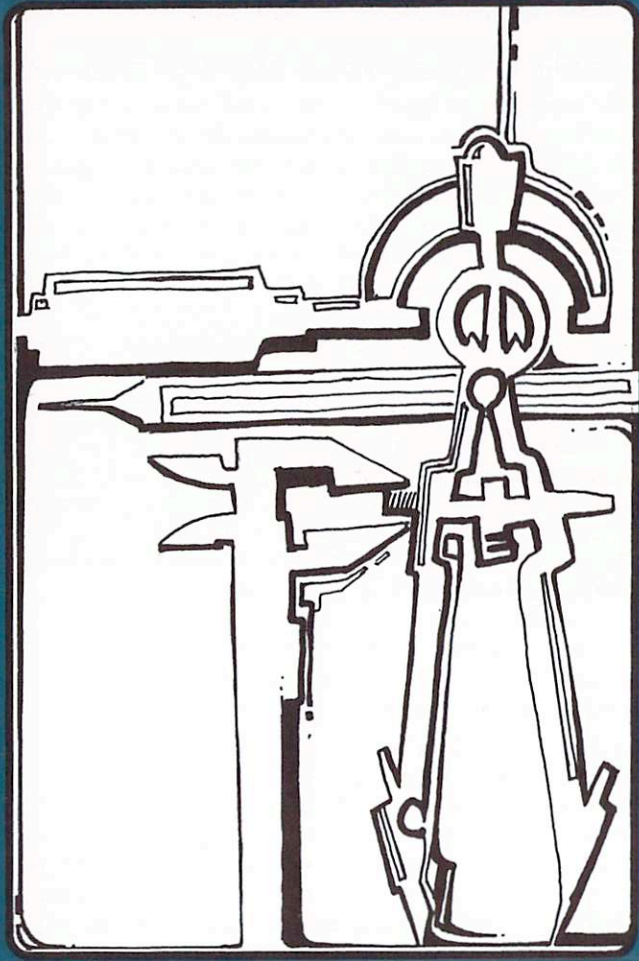

15

SPECIFICATIONS

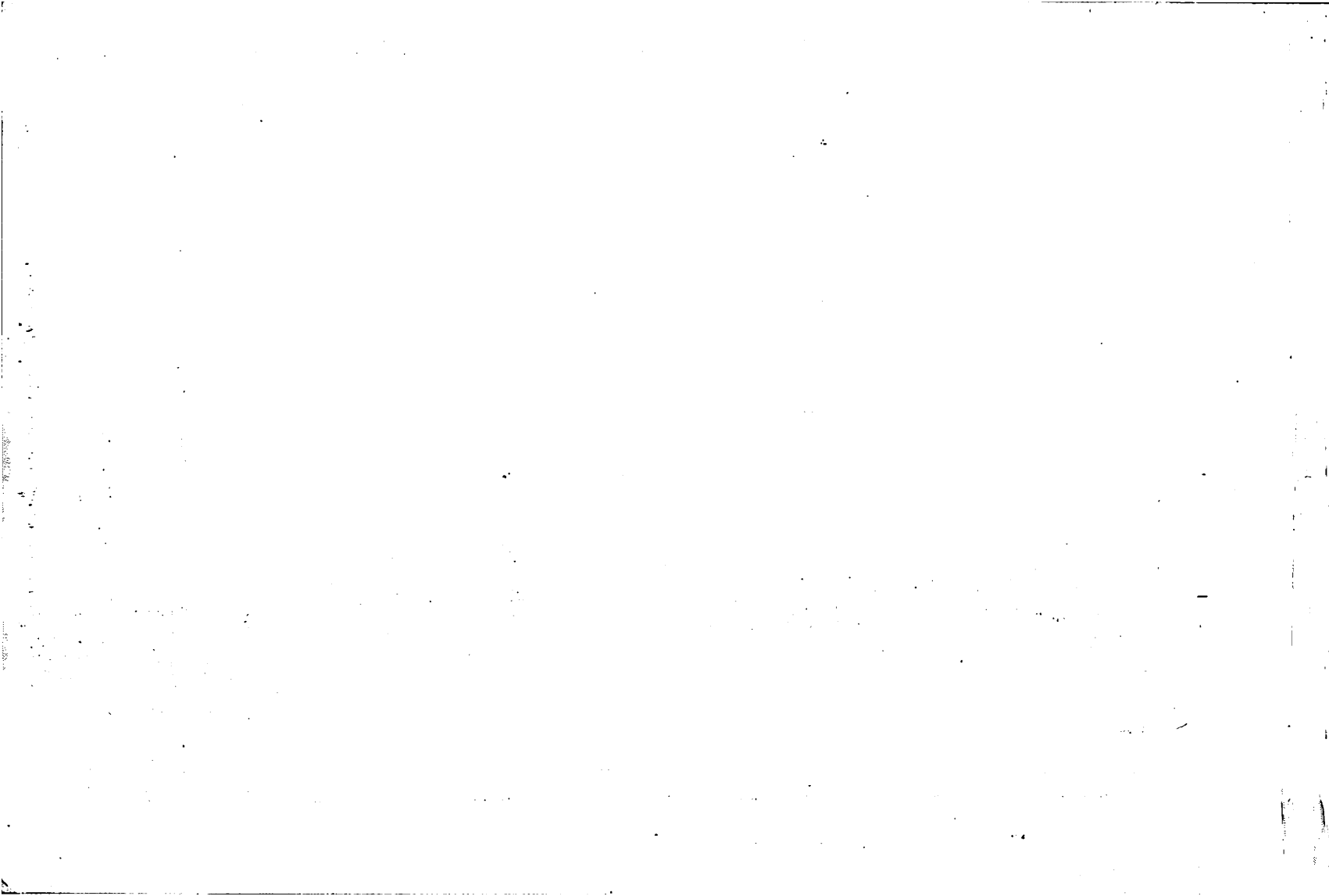

This chapter contains specifications for your particular Airstream trailer. In any communication with the factory, please be sure to include the serial number of your trailer. This serial number can be found stamped into the model and serial number plate which is mounted on the exterior of your Airstream just forward of the main door. A very helpful section of this chapter is that portion which

contains the charts that have the basic specifications about the running gear, appliances and various components of your trailer.

We suggest that you scan these charts so that when you have a particular need for information you will know where to look. The index will be helpful when looking for specific information.

SERIAL NUMBER

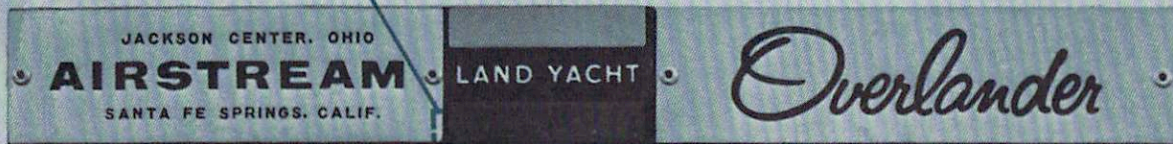

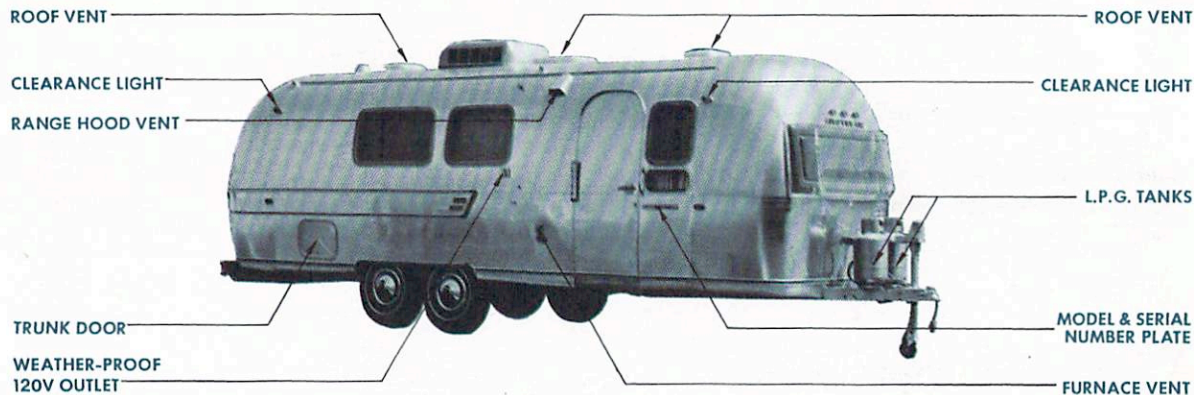

The first thing you should do in order to get the most carefree fun from your Airstream is to get to know it thoroughly. These photographs show a 27-foot International model. Regardless of the particular model or size of your Airstream, most of the details shown in the photographs apply.





This photograph shows the "One-Stop Service Center" This feature gives quick access for "hook-up" and service of most of the self-contained utilities in your trailer. Details of the utility systems are discussed in chapters 6 through 9 .

LICENSE PLATE LIGHT

TRAILER BATTERY

PRESSURE REGULATOR

DUMP VALVE HANDLE

FLUSHING FITTING

WATER LINE DRAIN VALVES

CITY WATER CONNECTION

SEWER HOSE STORAGE

ELECTRICAL CABLE

one stop service center

SPECIFICATIONS



B.T.U. RATINGS

APPLIANCE	MODEL	BTU
Furnace	23-ft. thru 27-ft.	22,000
	29-ft. thru 31-ft..	30,000
LPG Light	All Models	2,400
Oven (only)	All International	12,000
Range — Oven	All Land Yacht	39,000
Range (top only)	All International	19,500
Refrigerator	All Models	1,345
Water Heater	All Models	12,600

FUSES & CIRCUIT BREAKERS

CIRCUIT	LOCATION	RATING
Air conditioner	120 volt panel	15 amp C. B. (man. resetting)
Charge line from car fuse	One Stop Service Center	40 amp
Low voltage circuits	Central Control	20 amp C. B. (auto. resetting)
120 volt trailer circuits	120 volt panel (front roof locker) One Stop Service Center	20 amp C. B. (man. resetting)
12 volt main fuse	Central Control	40 amp

TIRE PRESSURE

7:75 x 15 8-ply	40 p.s.i.
7:00 x 15 8-ply (23-ft.)	60 p.s.i.
7:00 x 15 6-ply (25-ft. thru 31-ft.)	45 p.s.i.

CAPACITIES

APPLIANCE	CAPACITY
Waste Holding Tank	17 gal.
Water Tank	30 gal.
Water Heater	10 gal.

LIGHT BULB REPLACEMENT CHART

LOCATION	LAMP NUMBER
Back up Lights	1073
Bathroom light	1141IF
Ceiling fixtures (4 lamps each)	1141IF
Central Control panel light	NE51H
Clearance and Cluster	1889
Cone (bullet) lights (bedroom)	1176
Flood light	1034
License plate	89
Reading lights (Living Room)	1383
Stop & Turn signal	1034
Trunk compartment	1141

MOTOR AMPERAGE

Air conditioner	11.9 amps (55-amp starting load)
Ceiling fan	4.8 amps
Furnace blower and solenoid valve	4.5 amps
Range exhaust fan	2.0 amps
Toilet exhaust fan	2.0 amps
Water pump	4.7 amps at 5 psi to 7.3 amps at 40 psi

NOTE: If and when new materials and production techniques are developed which can improve the quality of its product, Airstream, Inc., reserves the right to make such changes.

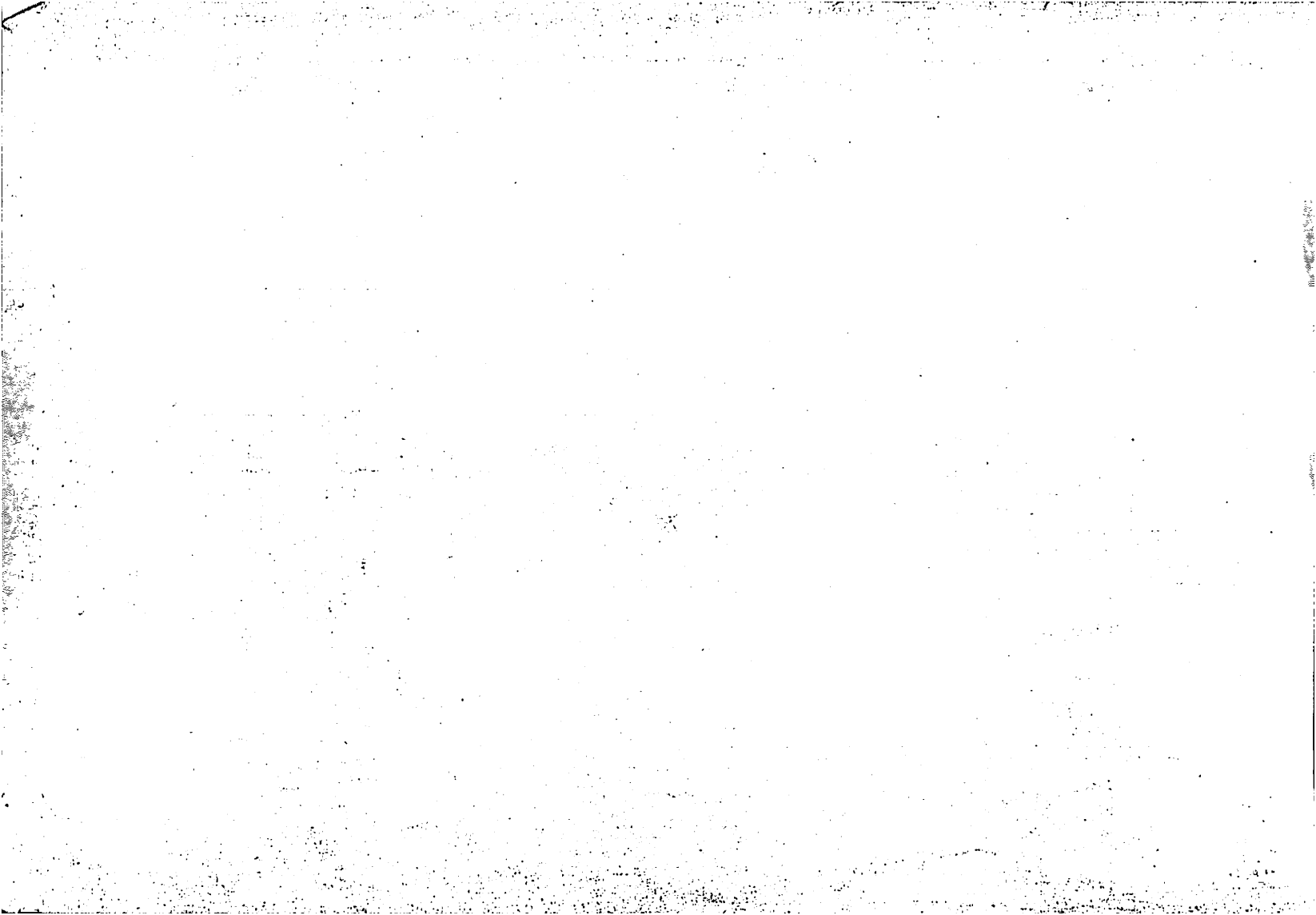

INDEX

ACCESSORIES	24, 25, 117	CEILING FANS	132	DUES CLUBS & MEMBERS	9
ADJUSTMENT OF BURNERS	ch. 10, 88	CEILING VENTS	104	DUMP VALVE	79
AIR CONDITIONER	24, 98, 132	CAPACITIES	132	DUMP VALVE LOCK	107
AMMETER	61	CENTRAL CONTROL PANEL	60, 132	ELECTRICAL CONNECTOR	29, 117, 121
APPLIANCES	ch. 10, 97-98, 132	CHASSIS AND HARDWARE (MAINTENANCE)	123, 124	ELECTRICAL DIAGRAMS	65, 66
AUTO	115	CHECK LIST: EQUIPMENT	23	ELECTRICAL PANEL (120v.)	62, 64, 65, 66
AWNING	25	HITCHING UP	29, 30	ELECTRICAL PANEL (12v.)	62, 64, 65, 66, 67
AXLE	101	HOME & TRAVEL	39	ELECTRICAL SYSTEM	ch. 7, 57-67
BACKING UP YOUR AIRSTREAM 35, 36, 37		MAINTENANCE	121	ELECTRIC BRAKES	101
BALANCE	31	STARTING OUT	30, 31	ELECTRIC JACK (HITCH)	25, 29
BALL, HITCH	115	CIRCUIT BREAKERS	62, 132	EQUIPMENT LIST	23
BASIC ELECTRICAL COMPONENTS	62	CITY POWER	59	EXHAUST HOOD, RANGE	96
BATTERY	60, 61, 112, 121	CLOCK	61	EXTENDED STAY	48, 49
BATTERY CHARGING (POWER)	60, 61	CLUBS	9, 10, 11	EXTENSION STEP	25
BATTERY CONDITION TESTER		COMPONENT LOCATION (ELECTRICAL)	62	EXTERIOR DETAILS	130
BEDS	106	CONNECTOR (ELECTRICAL)	29, 117, 121	EXTERIOR MAINTENANCE	122, 123
BRAKE-A-WAY SWITCH	29-30	CONVERTIBLE LOUNGES/BEDS	106	FACTORY SERVICE	15, 16, 17, 18, 19
BRAKE CONTROLLER	117	CREDENZA TABLE	105, 106	FAN SWITCH	90
BRAKES	101, 121	DEFROSTING	92	FILTER (AIR CONDITIONER)	98
B.T.U. RATINGS	132	DOORS	38, 103	FILTER (WATER)	72
BULBS (REPLACEMENT)	132	DOOR CATCHES	103	FLAT TIRES	102
BUNK BEDS	25	DRAINAGE SYSTEM	ch. 9, 77-84	FLEXIBLE STORAGE	105
BURNER ADJUSTMENT	88	DRAINAGE SYSTEM DIAGRAMS	83, 84	FLOORS	125
BUTANE SYSTEM	53	DRAINING DRAINAGE SYSTEM	79, 80, 111, 112	FLUSHING TOILET	79, 80
CARAVANS	9	DRAINING WATER SYSTEM	111	FOLDAWAY STEP	103, 121
CAR CONNECTOR	67	DRAPES & UPHOLSTERY	106, 125	FOREWORD	3
CAR EQUIPMENT	117	DRAWERS & SHELVES	105	FRONT TABLES	106
CAR-TRAILER ELECTRICAL CONNECTOR	15, 117, 121	DRIVING	32, 33, 34, 35	FURNACE BLOWER	132
CATCHES	104, 105				

FURNACES	87
FUSES	67, 132
GAS PIPING DIAGRAMS	54, 55, 56
GAS (L.P.G.) SYSTEM	ch. 6, 51-56
GAS TANK	53, 54, 55, 56
GAUCHO BEDS	25, 106
GOPHER HOLE	81
GROUNDING	62
HARDWARE	123, 124
HARD WATER FILMS	126
HEATER	87
HITCH	115
HITCH BALL HEIGHT	115
HITCH BALL LATCH	121
HITCHING UP	29
HITCH INSTALLATION	30, 115
HITCH JACK (ELECTRIC)	25, 29, 121
HOLDING TANK	79
HOLDING TANK LEVEL	62
HOME CHECK LIST	39
INTERIOR MAINTENANCE	125, 126
INTERIOR WALL FINISH	125
INTERIOR WOODWORK	125
JACKING TRAILER	29
JET SPRAY (TOILET)	80
LAST MINUTE ITEMS	39
LAVATORY AND TUB (MAINTENANCE)	...
LAWS	40, 41, 42, 43, 44
LEVELING	48
LEVELING BARS	30

LIGHT BULB (REPLACEMENT)	132
LIGHTING APPLIANCES	ch. 10
LIGHTS	59
LIGHT SWITCHES	59
LIMIT CONTROL	90
LOADING YOUR AIRSTREAM	31
LOCK (MAIN DOOR)	38, 103, 121
LOUNGES	106
LOW VOLTAGE PANEL	67
L.P.G. DIAGRAM	54, 55, 56
L.P.G. LIGHT	54, 55, 56, 132
L.P.G. SYSTEM	ch. 5, 53-56
LUBRICATION & MAINTENANCE	ch. 14
LUBRICATION (MISC. ITEMS)	121
LUG NUTS (WHEEL)	121
MAIN DOOR (LOCK)	38, 103, 121
MAINTENANCE	121
MAINTENANCE (EXTERIOR)	122
MAINTENANCE (GUIDE)	121
MAINTENANCE (INTERIOR)	125
MEDICINE CHEST	105
MICROSWITCH	90
MIRRORS (EXTERIOR)	117
MODEL IMPROVEMENTS	133
MODEL NO.	1
MOTOR AMPERAGES	132
MOTING ESSENTIALS	39
MULTI-DOME SYSTEM	62
ONE-STOP SERVICE CENTER	131
OPTIONAL EQUIPMENT	23, 117

OUTFITTING TRAILER	23
OVEN	94
OVERHEATING	38
OVERNIGHT STOP	47
PANEL LIGHT SWITCH	61
PARKING	36
PILOT ADJUSTMENT:	
FURNANCE (23 ft. thru 31 ft.)	87
OVEN	94
RANGE	94
REFRIGERATOR	91
WATER HEATER	97
POLARITY LIGHT	62
POWER ON	62
PRESSURE (TIRE)	102
PROPANE SYSTEM	53
PUMP (WATER)	73
PURIFIER	72
RADIO	24
RALLIES	9
RANGE	94
RANGE EXHAUST FAN	130
RANGE EXHAUST HOOD	96, 130
RANGE TOPS	94
REFRIGERATOR	91, 132
REGISTRATION	Inside Front Cover
REGULATOR (L.P.G.)	29, 53
REPAIR CENTERS	17, 18, 19
REMOVING MOISTURE	89
ROTATION OF TIRES	102

INDEX

INDEX

SCALE	126	TRAILER	101	VISTA VIEW WINDOWS	25
SAFARI BEDS	106	SWITCHES:		VENTS:	104
SCREEN DOOR	103	LIGHTS	59, 61	WALLY BYAM CARAVANS & CLUBS	9
SCREENS	104	UNIVOLT SYSTEM	59, 64	WARRANTIES:	
SCREEN (WATER)	71	SWAY CONTROL	116	BATTERY	60
SEALS (WINDOW)	124, 125	TABLE OF CONTENTS	5	TIRES	101
SEASONAL CHECK-UPS	122	TANK (SEWAGE)	62, 132	TRAILER	Inside Front Cover
SELF-CONTAINED (DRAINAGE)	79, 80	TANK (WATER)	71, 132	WATER DISTRIBUTION DIAGRAMS ..	74, 75
SELF-CONTAINED (ELECTRICAL)	59	TELEPHONE SHOWER HEAD	107	WATER DRAINAGE	
SEPTIC (HOLDING) TANK	79	TELEVISION	24	PROCEDURE	ch. 12, 111
SERIAL NUMBER	129	TIRE PRESSURE	101, 102, 132	WATER DRAIN VALVES	74, 75
SERVICE	ch. 2	TIRE ROTATION	102	WATER HEATER	77, 132
SERVICE CENTERS	17, 18, 19	TIRES	101	WATER LEVEL INDICATOR	61
SEWER CONNECTION	79	TOILET	80	WATER PUMP	73, 121, 132
SHOWER HEAD	107	TOILET EXHAUST FAN	98	WATER PUMP SWITCH	61
SIDE PULL-OUT BEDS	25, 106	TOW CAR	115	WATER PURIFIER (FILTER)	72
SINK MAINTENANCE	126	TOWING TIPS	32, 33, 34, 35	WATER SCREEN	71
SMOKE HOOD	96, 121	TOWING SKILLS	32, 33, 34, 35	WATER SYSTEM	ch. 8
SOLENOID VALVE	91, 132	TRAILER-CAR ELECTRICAL		WATER SYSTEM DIAGRAMS	74, 75
SPECIFICATIONS	ch. 15	CONNECTOR	29, 117	WATER TANK	71, 132
SPEED LAWS	40, 41, 42, 43, 44	TRAILER STORAGE-		WHEEL BEARINGS	121
STAINLESS SINKS (MAINTENANCE) ..	126	WINTERIZING	ch. 12	WHEELS	121
STARTING OUT CHECK LIST	30	TRANSMISSION COOLER	38	WINDOW (MAINTENANCE)	103, 124
STATE LAWS	40, 41, 42, 43, 44	TROUBLESHOOTING:		WINDOWS (OPERATION)	103, 104
STEP	103, 121	ELECTRICAL	63, 64	WINDOWS (REPLACEMENT)	124, 125
STEP EXTENSION	25	FURNACE	89	WINTERIZING	ch. 12
STEP FOLDAWAY	103, 121	RANGE & OVEN	94	WIRING	65, 66
STOPPING YOUR AIRSTREAM	35	REFRIGERATOR	92, 93	WORK SURFACES	125
STORAGE (TRAILER)	111	WATER SYSTEMS	73		
STOVE	94, 132	T.V. ANTENNA	107		
SUSPENSION:		UNIVOLT	59, 64		
CAR	116				

Black Plastic cloths line tied to
cross beam on awning

To Patch wheels - Pull tire 1st then hub 2nd
Get boards under R & L side and raise both at the
same time.

Spur Tire - a tube tire with split rim 38 lbs

Turnover - To start flush with foot or
use screw driver handle in cardboard.

Back gears - On ground 25 cranks

On cement 15 cranks
(or just crank up tight)

Iron Chain - same a lot of sand - trailer
Can

Hot Water Tank - below warm

Center vent - when loose just flush in top
hole to faster - 15 turns

Refrigerator - To light Pilot use pencil
to flush bottom and
turn thermostat up as high as it will go.

Copper water lines $\frac{1}{2}$ "

Hoses for water lines $\frac{3}{4}$ " or $\frac{5}{8}$ "

~~Put~~ Sofa - put flag pole tight
against arm rest under mattress to whole
" wall

Shower head: take off & clean to stop
drizzling

~~_____~~

LITHO USA 1968